

RELAY CATALOG





SAFRAN

SAFRAN ELECTRICAL & POWER

**SMARTER ELECTRICAL SOLUTIONS FOR
A BETTER FLIGHT**

**At Power we innovate to provide
greener, reliable and cost-effective
electrical solutions. We are one
division "Powering-On" to be a world
class trusted supplier.**

Table of Contents

3	Table of Contents
4	Fast Information Finder
4	Part Number to Page Index
5-8	Capabilities and Featured Products Safran Electrical & Power Capabilities Featured Products Article (High Volt DC / Next Generation Contactors / Power Distribution Boxes)
9-20	Remote Controlled Circuit Breakers Remote Controlled Circuit Breakers Remote Power Controllers
21-30	Power Relays Gasket Sealed - 100 to 1000A Gasket Sealed - 25 to 400A, Type II and Type III
31-37	Hermetically Sealed Power Relays Hermetically Sealed - 12 to 50A Hermetically Sealed - 100 to 400A Terminal Covers
38-41	Lightweight Relays Hermetically Sealed Environmentally Sealed
42-43	Generator Contactors
44-46	Custom Flat Packs
46	Reference Military to Safran Electrical & Power Part Number Index

Capabilities and Featured Products

Remote Controlled Circuit Breakers

Power Relays

Hermetically Sealed Power Relays

Lightweight Relays

Generator Contactors

Custom Flat Packs

Reference

Find Information Fast

- **Have a Safran Electrical & Power part number and need more information?** Use the part number to page index on this page to get the exact page of the full product listing.
- **Have a Military part number and need applicable Safran Electrical & Power part number?** Use the Military part number Index in the back of this catalog.
- **Need additional information not contained in this catalog?** For technical questions, application assistance, or the name of your local authorized distributor, call 1-800-955-7354.

Part Number to Page Index

Safran Electrical & Power Part

No.	Page No.
49-	36
6041H-	25
6042H-	31
6046H-	25
9565H	25
SM15	40
SM100D-	21
SM150D-	21
SM200D-	21
SM400D-	21
SM1000D-	21
SM135B2	42
SM400H	34
SM600BA5 - 100	10
SM600BA125 - 200	19
SM601BA10 - 60	10

Market Trends

Aircraft and commercial off-highway vehicle Original Equipment Manufacturers (OEMs) are continuously pursuing efficiencies associated with the design and manufacture of vehicle platforms. Additionally, the OEMs are working on increasing the functionality of system components while reducing operating and life cycle costs. These activities are leading to the migration of engineering and system design activities to Tier 1 system integrators and their supply partners such as SafranElectrical&Power. This supplier team will be required to design, develop, and manufacture performance rated products such as relays, "smart" contactors, high voltage DC contactors, and power distribution junction boxes that minimize cost, reduce weight, and limit product dimensions in order to support accomplishing OEM objectives.

What Problem Does Safran Electrical & Power Systems Solve?

Aircraft OEMs discovered that outsourcing power distribution management requirements to Tier 1-system integrators and their vendor base is an effective alternative that mitigates risk and leverages the subsystem and component manufacturer expertise. The success of such outsourcing efforts benefits the OEM and leads to more reliance on qualified Tier 1-System Integrators for electrical systems. To compliment this OEM strategy, Safran Electrical&Power formed the product division, which combines the product pedigree of illuminated pushbutton switches, cockpit displays and keyboards, NVIS products, pilot controls, and a variety of MIL-qualified aerospace switches,

relays, contactors, and circuit breakers, to broaden the product portfolio and support execution of a subsystem strategy. Safran Electrical&Power's objective is to be the leading candidate for the supply of aerospace power distribution components and subsystems.

The Safran Electrical & Power Solution

SafranElectrical&Power is an attractive partner in the design and development of integrated relay and contactor components and subsystem power junction boxes. Our development process employs sound methodology to identify, assess, and manage program risk. The components of this approach include [Phase-Gate Reviews](#), [Project Management](#), and [Six Sigma for Design and Development](#). This process in conjunction with Safran Electrical&Power's extensive Product Portfolio and Capabilities enable the Aerospace Group division to be a single source supplier for power protection, distribution, and switching components. The system integrators have the option of sourcing pedigree relays and contactors for their power distribution box designs or subcontracting the entire power distribution subsystem to Safran Electrical & Power.

Phase-Gate Reviews

This process organizes product development activities from the idea through product launch into a series of phases. The activities within each phase are multifunctional, and are designed to provide information that progressively reduces risk. Consistent application of the process promotes successful on-time product development, as well as competitive pricing and high quality levels.



Project Management

Product development projects involve the iterative planning, execution and control of project team activities in order to meet the competing demands of scope, timing, cost, risk and quality. Project management methodology affords the application of knowledge, skills, tools and techniques to meet these requirements.

Six Sigma for Design and Development

Six Sigma for Design and Development is a methodology using normal Six Sigma tools, but applies them early in the design process. This methodology instills the product development process with the same Six Sigma process rigor found in SafranElectrical&Power manufacturing to create successful products in a competitive marketplace.

Product Portfolio

SafranElectrical&Power's complete product portfolio allows flexibility to partner with customers having a variety of relay and contactor subsystem and component needs. Safran Electrical&Power's engineers design additional value into traditional power distribution components and subsystems through electronics, while balancing customer concerns for size, weight, cost, and performance. SafranElectrical&Power's Power Distribution



Boxes are a prime example of value-added engineering. Proven relay, contactor, and circuit breaker products are packaged into a single line replaceable assembly that offers the user a customized power module that significantly reduces overall system weight, improves system level reliability, and maintainability.

The Safran Electrical & Power product portfolio is recognized in the aerospace industry as MIL qualified for performance rated power distribution products. Safran Electrical & Power's experience in designing relays and contactors to MIL Spec requirements such as MIL-PRF-83383, MIL-R-6106/9, /10, /11, and MIL-R-6101/48 ensures the customer of relays and contactors that will operate in the most challenging environments and in accordance with the strictest performance requirements. These same component design considerations are incorporated into Safran Electrical & Power's latest designs such as High Voltage DC Contactors and also in subsystem designs such as a Power Distribution Box (PDB). These products are highlighted in the **Featured Products Article** on page 7-8.

The product portfolio includes:

- Smart Contactors with current sensing protection, Ground Fault Interrupt technology, or Arc Fault Circuit Interrupt technology.
- 28 Vdc Contactors (50 to 1000 amperes).
- 270 Vdc Contactors (25 to 350 amperes).
- 115/230 Vac 400 Hertz Contactors (30 to 430 amperes).
- 750 Vdc Contactors (100 to 600 amperes).
- Power Distribution Junction Boxes.
- A variety of aerospace switches (rocker, toggle, pushbutton and limit)
- Pilot Controls including customized flap controls, landing gear controls, throttle controls, trim controls (for mechanical pitch, roll and yaw), and fire emergency controls.
- Displays, readable in both direct sunlight and at night, including the popular Series 900 fiber optic displays, as well as displays with surface mount devices and programmable electronic arrays.
- Keyboards that are sunlight and night light readable and suited for virtually any application, including flight management panels, handheld data communications panels, shipboard computer control panels, fire system control panels, ground support equipment, and radar and telemetry control panels. Safran Electrical & Power keyboards also incorporate logic boards, photo sensors, rotary and toggle switches, and annunciators, and have features such as micro-processor interfacing and programmable logic control.

- NVIS products such as cockpit controls, displays and keyboards, and illuminated push button switches that conform to MIL and NVIS specifications and any unique customer needs.
- Illuminated Pushbutton switches with a multitude of options ranging from sunlight readable, NVIS-compatible, incandescent and LED lighting to various mounting and termination options for flexible installation and retrofit applications.
- Electro-mechanical thermal circuit breakers (0.5 to 300 amperes) - single phase or three phase thermally actuated devices offered in conventional design or with integrated Arc Fault Circuit Interrupt technology.
- Remote Control Circuit Breakers (5 to 125 amperes) - single phase or three-phase devices sold separately or as a subsystem when combined with a necessary indicator control unit (0.5 ampere circuit breaker).
- Electromechanical Remote Power Controllers (125 to 200 amperes) - single-phase devices sold separately or as a subsystem when combined with a necessary indicator control unit (0.5 ampere circuit breaker).

Safran Electrical & Power Capabilities

- Proven excellence in component and subsystem design, development, testing, qualification, and production for both military and commercial aerospace applications.
- A manufacturing organization that emphasizes customer satisfaction by focusing on cost, quality, and delivery of the product portfolio.

- Altitude / temperature testing chamber simulating altitude to 80,000 feet and temperatures from -65°C to 125°C.
- Test capabilities of 115/200 Vac 400 Hz to 3600 amps, 28 Vdc to 10,000 amps, 270/350/475 Vdc to 1,500 amps.
- Environmental tests for Sand and Dust, Shock, and Vibration.
- Latest CAD/CAM finite element analysis and stereolithographic techniques, and PRO-E design.
- Model Shop flexibility to respond to design changes and rapid turn around of prototypes.

The Safran Electrical & Power Difference

There are a number of relay and contactor suppliers in the aerospace market. However, few possess the vertical integration needed to engineer and manufacture to both MIL Spec and OEM customer specifications to ensure consistency of quality operation in components and subsystems.

SafranElectrical&Power affords its customers the following difference:

- Strong brand recognition, customer loyalty, and demonstrated market presence for over 80 years
- Ability to leverage the company's size, financial strength, and scope to drive superior results. Safran Electrical & Power has the ability to leverage the engineering resources of a multi-billion dollar company.
- An extensive product portfolio that complements integrated subsystem design competency.

- A flat organizational structure that allows for the optimal blend of best value technical approach and test support within budget and schedule constraints.
- Dedicated program managers that understand and communicate the "voice of the customer". Design software that promotes concurrent engineering and the exchange of customer data.
- Co-located engineering, manufacturing, and development resources promote robust product development and product support.

Safran Electrical & Power's unique portfolio, its ability to design and manufacture components and subsystems, and customer centric strategy mitigates the risk associated with new aircraft electrical power distribution systems. Safran Electrical & Power is an ideal candidate to consider for engineering and manufacturing collaboration on all future commercial, General Aviation, and military programs.



Changing Aerospace Industry

In today's consolidating aerospace industry, Tier 1-System Integrators and Airframe Manufacturers desire more value from their component suppliers. A qualified supplier must not only have an extensive product portfolio, but must also display proven subsystem capabilities. These abilities include the capacity to design, manufacture, and test customized power distribution assemblies that consolidate multiple functions in a single package. Over the past decade, Safran Electrical & Power acknowledged this fact, and has focused its attention on developing these value-add competencies to become a recognized leader in integrated power distribution systems. Specifically, Safran Electrical & Power has stayed at the forefront of product / technology development through the development of the following components and subassemblies: High-Voltage DC (HVDC) Contactors, Next-Generation Alternating Current (AC) Contactors, and Power Distribution Boxes.

High-Voltage DC Contactors



As electrical power systems of 270Vdc and greater become the application standard for high performance aircraft, the requirements for switching and protection components become

increasingly demanding. DC switching has always posed greater design challenges versus AC applications. With AC, the current naturally passes through zero each half cycle resulting in quick arc extinction after contact separation.

Conventional 28Vdc switching can also be accomplished using single or double break contact sets. In this case, the inherent arc voltage generated by the anode and cathode of the arcing contact sets is capable of opposing and interrupting the current flow. The low voltage device counts little on the arc voltage generated in the actual arc column to drive the current to zero.

Once the system voltage is increased beyond the 48Vdc rating, the interruption scheme becomes more challenging. Although the arc voltage generated by the arc column is generally small compared to the anode and cathode voltages, it will increase as the open contact gap widens. The actual arc voltage generated is a function of contact materials, the gas or atmosphere in the contact region, application current, and contact gap. Unfortunately, there is zero crossover to facilitate interruption, and the design must rely on open gap or arc stretching to match the system voltage. Therefore, with a single or double break contact set, the ability to interrupt 270Vdc quickly becomes size impractical without a more involved interruption scheme.

Safran Electrical & Power Technical Approach

The technology chosen for use within the Safran Electrical & Power line of 270Vdc contactors is splitting the arc into multiple series arcs under the

influence of a constant magnetic field. This is accomplished by driving the arc column into a set of metallic plates housed within an insulated arc chute assembly. The multiple plates then provide the significant anode and cathode contribution to the arc voltage required for interruption. The plates also help to cool the arc column, causing the arc to exist at a higher potential and be stabilized in a predictable location in the plate. By placing multiple plates within the arc chute, the arc voltage generated during interruption can be increased resulting in less volume required by the arc chute.

With the use of permanent magnets for controlling the arc column, the interruption is consistent even at low levels of application current. This results in extended low-level contact life. This design allows for smaller device size and the ability to mount the products in a compact power distribution subsystem.

Benefits of HVDC Technology

The Aerospace Group's ES&C division has long been involved in programs addressing requirements for High Voltage Direct Current (HVDC) applications. Few competitors rival Safran Electrical & Power's knowledge and experience in this technology over the past two decades. The proven air break technology used by the Safran Electrical & Power HVDC contactor line provides the following benefits that competitive HVDC product offerings (hermetic) do not provide:

- Safran Electrical & Power was the first contactor manufacturer to complete product design and flight safety tests for 270Vdc aerospace devices.

- Hermetic sealing material adds unnecessary device weight. Hermetic sealing material degrades over time compromising the controlled atmosphere within the arc chamber, potentially leading to device failures. Safran Electrical & Power devices have no requirement for a seal.
- Hermetic sealed devices are classified by an allowable leakage rate, suggesting they are inherently unstable over time and susceptible to "dormant" failures. The Safran Electrical & Power design increases reliability because the splitter plates eliminate single point of failure (inability to interrupt) associated with failed hermetic devices.
- Load Polarity - Safran Electrical & Power's devices are bi-directional without restriction. Safran Electrical & Power devices reliably switch small current loads as well as high current loads.
- Electrical Life - Safran Electrical & Power end of life characterized by contact voltage drop.
- Safran Electrical & Power's design is robust and operates well in harsh environments as demonstrated by past program performance and application of commercialized product.
- Safran Electrical & Power's device is a "Qualified" technology per MIL-R-6106 standard for all contactors.
- Safran Electrical & Power's device packaging easily tailored for application footprint.
- Increased capability to dissipate energy for switching inductive loads.
- Consistent and controlled switching transients due to ramped build up of arc voltage upon interruption.
- Line Replaceable Unit packaging minimizes maintenance time.

The Safran Electrical & Power design does not require a hermetic seal, providing several advantages in application. In military applications, the use of splitter plate technology allows the device to function reliably throughout the life of the airframe while being subjected to harsh combat field environments and flight profiles that involve extreme levels of vibration and shock that can compromise competitors' hermetic seal product designs. The loss of a hermetic seal causes device failure as it relies on the sealed atmosphere within the device to interrupt high voltage. A failure of this nature could cause mission cancellation, mission abort, or even loss of aircraft. If installed in commercial aircraft applications, hermetically sealed devices would require periodic maintenance crew checks to prevent the risk of "dormant" failures associated with this design. The Safran Electrical & Power design reduces/eliminates the need for maintenance involvement and better supports Air Carrier objectives for maintenance-free devices.

Combining ongoing research with current product development, Safran Electrical & Power continually strives to be a premier supplier of High-Voltage DC components and subsystems.

Next Generation Contactors

Safran Electrical & Power has extensive experience in the research, design, and development of various AC Contactor product lines, including "Smart" contactors with integrated current sensing and Arc Fault Circuit interrupt (AFCI) technology, 28Vdc Lightweight

Contactors, and Advanced Generator Contactors.

"Smart" Contactors

Safran Electrical & Power is currently developing 175/60 amp packages for galleys, pumps, and primary load distribution. These contactors use the latest technologies, and can include current sensors for overcurrent protection and/or AFCI sensing. Internal / centralized electronics control are also features of these devices. Safran Electrical & Power is continually looking for lower weight / size product solutions; a prime example being the 60 amp "Smart" contactor that is currently no bigger than a Safran Electrical & Power 3-phase motor circuit protection device.

28Vdc Lightweight Contactors

Safran Electrical & Power is also developing a new 28Vdc, 50-400 Amp contactor family whose focus is on the reduction of weight and cost. Bolt-on designs combine power terminations and mechanical mounting, and contain captive hardware for all mounting fasteners. Both Single Pole Single Throw and Single Pole Double Throw configurations are available with features such as SubD or sealed in-line connectors.

Advanced Generator Contactors



Based upon the existing SM15 product line, a new AC Generator contactor line of products is emerging. These contactors have automatic control connector

mating and either Three Pole Single Throw or Three Pole Double Throw main contacts. Safran Electrical & Power offers 115 VAC or 230 VAC (350-800Hz) generator contactors that are bolt-on designs with SubD connectors and rated at either 260 amps or 430 amps. They are currently one of the smallest and lightest AC contactors in the aerospace generator relay market, accommodate Variable Frequency and double voltage aircraft architectures, and are suitable for either stand-alone applications or power distribution boxes.

Power Distribution Boxes



Safran Electrical & Power's proven component expertise and packaging capabilities have allowed ES&C to become a subsystem supplier in both the commercial jet and military aircraft markets. An example of these competencies is evident in the development of ED&C Power Distribution Boxes. A Power Distribution Box provides the next generation of AC and DC power distribution and protection, whereby conventional relays, contactors, and circuit protection devices are incorporated into a densely packaged, single line replaceable assembly. Benefits of this type of bundled packaging include weight reduction, reduced maintenance labor time due to the line replaceable nature of these boxes, minimal program risk since commercially off the shelf components are

incorporated as often as possible into the design, significantly lower on-aircraft test time since they are tested to the customer acceptance testing standards prior to shipment, and reduced overall aircraft build time since Power Distribution Boxes support a centralized power distribution architecture.

Power Distribution Boxes (PDBs) are typically designed and manufactured for each of the main generators onboard an aircraft in order to provide power to various bus lines and aircraft systems, while other, separate Battery/ External PDBs can provide switching power to a standby power bus and several components such as overhead panels, service lights, and the emergency locator transmitter.

Safran Electrical & Power has supplied customers with AC Power Distribution Boxes with features that direct outputs to high current loads, serve as power feeders to lower current circuit breakers, or act as current transformers to monitor all outputs. DC Power Distribution Boxes contain such features as Transformer Rectifier Units and Battery Contactors that direct outputs to high current loads, and incorporate Hall Effect sensors to monitor outputs. All Power Distribution Boxes can incorporate customized current carrying bus structures, and provide spare electrical power generation capacity to support future electrical systems growth.





Single Pole

- 28 VDC
- 115/200 VAC 400 Hz



Three Phase

- 115/200 VAC 400 Hz
- Three Phase Only

Qualified

Qualified to demanding performance parameters of MIL-PRF - 83383 standard.

Use as a Relay, Circuit Breaker, Or Both

RCCBs combine the best attributes of a circuit breaker and a relay. Automatically protects the wires and the load device during circuit/load breakdown, but allows the flight deck control of the load during normal operation.

Weight and Cost Savings

In distributed-load applications, RCCBs are a more efficient power distribution solution promoting cost and weight savings through the elimination of long runs of heavy cables associated with the conventional relay - flight deck circuit protector method. Control of the RCCB requires only one #22 AWG control wire from the ICU on the flight deck to the RCCB.

Cockpit Space Savings

An RCCB system removes the presence of large circuit breakers from the cockpit while permitting remote On/Off operation from the flight deck. Combine Safran Electrical & Power RCCB with Indicator Control Unit (ICU) model #1500-052-05.

PERFORMANCE DATA

Rupture Levels	3600 A (115 VAC or 28VDC for 1 Pole and 115VAC for 3 Pole)
Endurance (Resistive & Inductive (Motor))	50,000 Cycles
Endurance (Motor)	5-50A: 50,000 cycles; 60-100A: 25,000 cycles
Endurance (Lamp)	5-25A: 50,000 cycles; 35-50A: 25,000 cycles; 60-100A: no rating
Dielectric Strength	1500V, 60 Hz, MIL-STD-202, method 301, 0.5 MA max
Insulation Resistance	100 mega ohm min, MIL-STD-202, method 302
Thermal Temperature Range	-54°C to 71°C (-65°F to 160°F). MIL-STD-202, Method 107
Vibration	10G's to 2000 Hz. Exceeds MIL-STD-202, Method 204, Condition C, 10 microseconds max. chatter
Shock	25G's. MIL-STD-202, Method 213, 10 microseconds max. chatter
Altitude	50,000 ft.
EMI Requirements	MIL-STD-461, Requirements CS114 and RE102 over the frequency range of 14 kHz to 400 MHz and RE102 limits for Aircraft and Space Systems.
EMI/RFI Susceptibility and Generation	MIL-STD-461, Class 1D
Moisture Resistance	MIL-STD-202, method 106
Salt Spray Resistance	MIL-STD-202, method 101, Condition B
Sand and Dust Resistance	MIL-STD-202, method 110, Condition A
Fungus Resistance	MIL-HDBK-454, Guideline 4
Explosion Proof	MIL-STD-202, method 109
Weight (Single Pole)	5-25A: 318 grams (0.703 lbs.); 35-50A: 325 grams (0.719 lbs.); 60-100A: 332 grams (0.734 lbs.)
Weight (w/ Auxiliary Contacts)	5-25A: 332 grams (0.734 lbs.); 35-50A: 339 grams (0.750 lbs.); 60-100A: 346 grams (0.766 lbs.)
Weight (Three Phase)	2.0 lbs. max.

OVERLOAD CALIBRATION DATA

Specification Table	@ 25°C		@ +71°C		@ -54°C		Test Time Parameters
	MIN	MAX	MIN	MAX	MIN	MAX	
Must Hold	115%		115%		115%		% for 1 Hour
Must Trip		138%		138%		150%	% Within 1 Hour

REMOTE CONTROLLED CIRCUIT BREAKER (RCCB)

Engineering Data

Single Pole Single Throw (Double Break Contacts)

Catalog Number ^①	Rated Contact Load (Amperes)								MIL-PRF-83383 Part Number	Maximum Weight Oz/gm
	28 Vdc				115/200 V 400 Hz					
	Res.	Ind.	Motor	Lamp	Res.	Ind.	Motor	Lamp		
SM600BA5A1	5	5	5	5	5	5	5	5	M83383/02-01	11.75/332
SM600BA5N1									M83383/01-02	11.25/318
SM600BA10A1	10	10	10	10	10	10	10	10	M83383/02-03	11.75/332
SM600BA10N1									M83383/01-03	11.25/318
SM600BA15A1	15	15	15	15	15	15	15	15	M83383/02-04	11.75/332
SM600BA15N1									M83383/01-04	11.25/318
SM600BA20A1	20	20	20	20	20	20	20	20	M83383/02-05	11.75/332
SM600BA20N1									M83383/01-05	11.25/318
SM600BA25A1	25	25	25	25	25	25	25	25	M83383/02-06	11.75/332
SM600BA25N1									M83383/01-06	11.25/318
SM600BA35A1	35	35	35	35	35	35	35	35	M83383/02-07	12.00/339
SM600BA35N1									M83383/01-07	11.50/325
SM600BA40A1	40	40	40	40	40	40	40	40	M83383/02-08	12.00/339
SM600BA40N1									M83383/01-08	11.50/325
SM600BA50A1	50	50	50	50	50	50	50	50	M83383/02-09	12.00/339
SM600BA50N1									M83383/01-09	11.50/325
SM600BA60A1	60	60	60	—	60	60	60	—	M8338/02-10	12.25/346
SM600BA60N1									M83383/01-10	11.75/332
SM600BA75A1	75	75	75	—	75	75	75	—	M83383/02-11	12.25/346
SM600BA75N1									M83383/01-11	11.75/332
SM600BA100A1	100	100	100	—	100	100	100	—	M83383/02-13	12.25/346
SM600BA100N1									M83383/01-13	11.75/332

Three Pole Single Throw (Double Break Contacts)

Catalog Number ^①	Rated Contact Load (Amperes)				MIL-PRF-83383 Part Number
	115/200 V 400 Hz				
	Res.	Ind.	Motor	Lamp	
SM601BA10A1	10	10	10	10	M83383/04-03
SM601BA15A1	15	15	15	15	
SM601BA20A1	20	20	20	20	M83383/04-05
SM601BA25A1	25	25	25	25	
SM601BA35A1	35	35	35	35	M83383/04-07
SM601BA40A1	40	40	40	40	M83383/04-08
SM601BA50A1	50	50	50	50	
SM601BA60A1	60	60	60	60	M83383/04-10

① Contact factory on alternate amperage, trip times, control configurations, grounding, auxiliary switches, and mounting systems.

ORDERING INFORMATION

AMPERE RATING	Single Pole Single Throw (Double Break Contacts)				Three Pole Single Throw (Double Break Contacts)	
	Standard		w/ Auxiliary Contacts		w/ Auxiliary Contacts	
	MS P/N	Safran Electrical & Power P/N	MS P/N	Safran Electrical & Power P/N	MS P/N	Safran Electrical & Power P/N
5	M83383/01-01	SM600BA5N1	M83383/02-01	SM600BA5A1		**
7.5		**		**		**
10	M83383/01-03	SM600BA10N1	M83383/02-03	SM600BA10A1	M83383/04-03	SM601BA10A1
15	M83383/01-04	SM600BA15N1	M83383/02-04	SM600BA15A1		SM601BA15A1
20	M83383/01-05	SM600BA20N1	M83383/02-05	SM600BA20A1	M83383/04-05	SM601BA20A1
25	M83383/01-06	SM600BA25N1	M83383/02-06	SM600BA25A1		SM601BA25A1
35	M83383/01-07	SM600BA35N1	M83383/02-07	SM600BA35A1	M83383/04-07	SM601BA35A1
40	M83383/01-08	SM600BA40N1	M83383/02-08	SM600BA40A1	M83383/04-08	SM601BA40A1
50	M83383/01-09	SM600BA50N1	M83383/02-09	SM600BA50A1		SM601BA50A1
60	* M83383/01-10	SM600BA60N1	M83383/02-10	SM600BA60A1	M83383/04-10	SM601BA60A1
75	* M83383/01-11	SM600BA75N1	M83383/02-11	SM600BA75A1		
80	*	**		**		
100	* M83383/01-13	SM600BA100N1	M83383/02-13	SM600BA100A1		

All Ampere Ratings equal to Rated Contact Loads (Resistive, Inductive, Motor, and Lamp) except as noted.
 * No Lamp Load Rating
 ** Contact Factory
 Note: Contact factory on alternate amperage, trip times, control configurations, grounding, auxiliary switches, mounting systems, etc.

SINGLE POLE

OVERLOAD CALIBRATION DATA

Ratings	Percent Rated Current	Ambient Temperature Degrees C. ± 5°	Tripping Time
All	115%	25°C & 71°C	No Trip
	138%		1 Hour Max.*
	115%	-54°C	No Trip
	150%		1 Hour Max.*

* Must trip in one hour.

OVERLOAD CALIBRATION DATA – SINGLE POLE

AMPERE RATING	200% Trip Times -54°C to +71°C		400% Trip Times -54°C to +71°C		1000% Trip Times -54°C to +71°C	
	MIN	MAX	MIN	MAX	MIN	MAX
	SECONDS	SECONDS	SECONDS	SECONDS	SECONDS	SECONDS
5	7	40	1.2	6.4	0.3	1.2
7.5	11	40	2.4	6.8	0.33	1.1
10	12	42	2.8	8.5	0.42	1.05
15	13	45	1.7	8.3	0.35	1.2
20	14	46	2.9	7.6	0.4	1.15
25	15	50	2.6	8.7	0.4	1.3
35	16	55	2.8	8.3	0.35	1.3
40	16	55	2.9	9.2	0.36	1.3
50	13	55	2.9	10	0.4	1.25
60	13	60	2.6	13	0.26	1.8
75	13	60	2.5	13	0.26	1.8
80	14	60	2.7	12.5	0.3	2
100	17	63	3.5	13	0.38	1.9

TRIP CURVE

Contact business unit for trip curve.

TRIPLE POLE

OVERLOAD CALIBRATION DATA

Ratings	Percent Rated Current	Ambient Temperature Degrees C. ± 5°	Tripping Time
All	115%	25°C & 71°C	No Trip
	138%		1 Hour Max.*
	115%	-54°C	No Trip
	150%		1 Hour Max.*

* Must trip in one hour.

OVERLOAD CALIBRATION DATA – THREE POLE

AMPERE RATING	200% Trip Times -54°C to +71°C		400% Trip Times -54°C to +71°C		1000% Trip Times -54°C to +71°C	
	MIN	MAX	MIN	MAX	MIN	MAX
	SECONDS	SECONDS	SECONDS	SECONDS	SECONDS	SECONDS
10	12	80	2.8	11	0.42	1.3
15	13	80	1.7	10	0.35	1.2
20	14	80	2.9	9.6	0.4	1.15
25	15	80	2.6	10	0.4	1.3
35	16	80	2.8	11	0.35	1.3
40	16	80	2.6	10	0.36	1.3
50	13	80	2.9	10	0.4	1.25
60	13	80	2.4	16	0.26	1.8

REMOTE CONTROLLED CIRCUIT BREAKER (RCCB)

Engineering Data Application Note

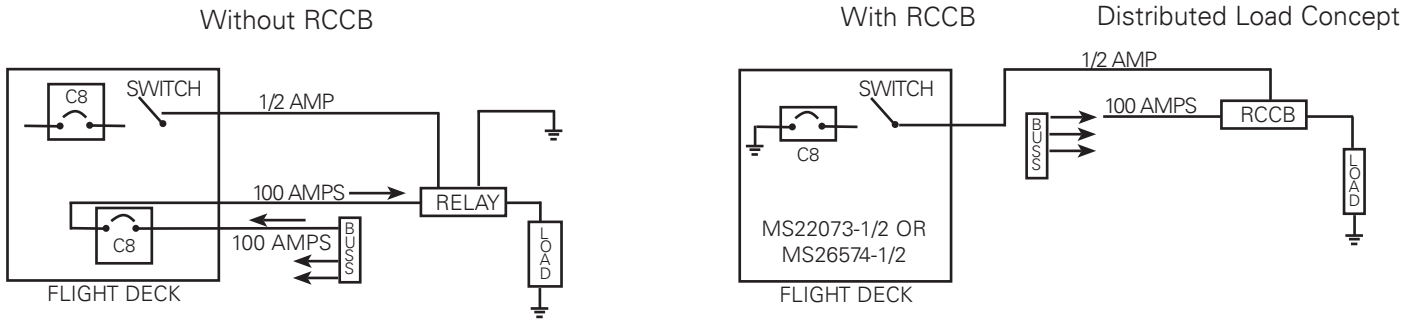

Typical Wiring Diagrams

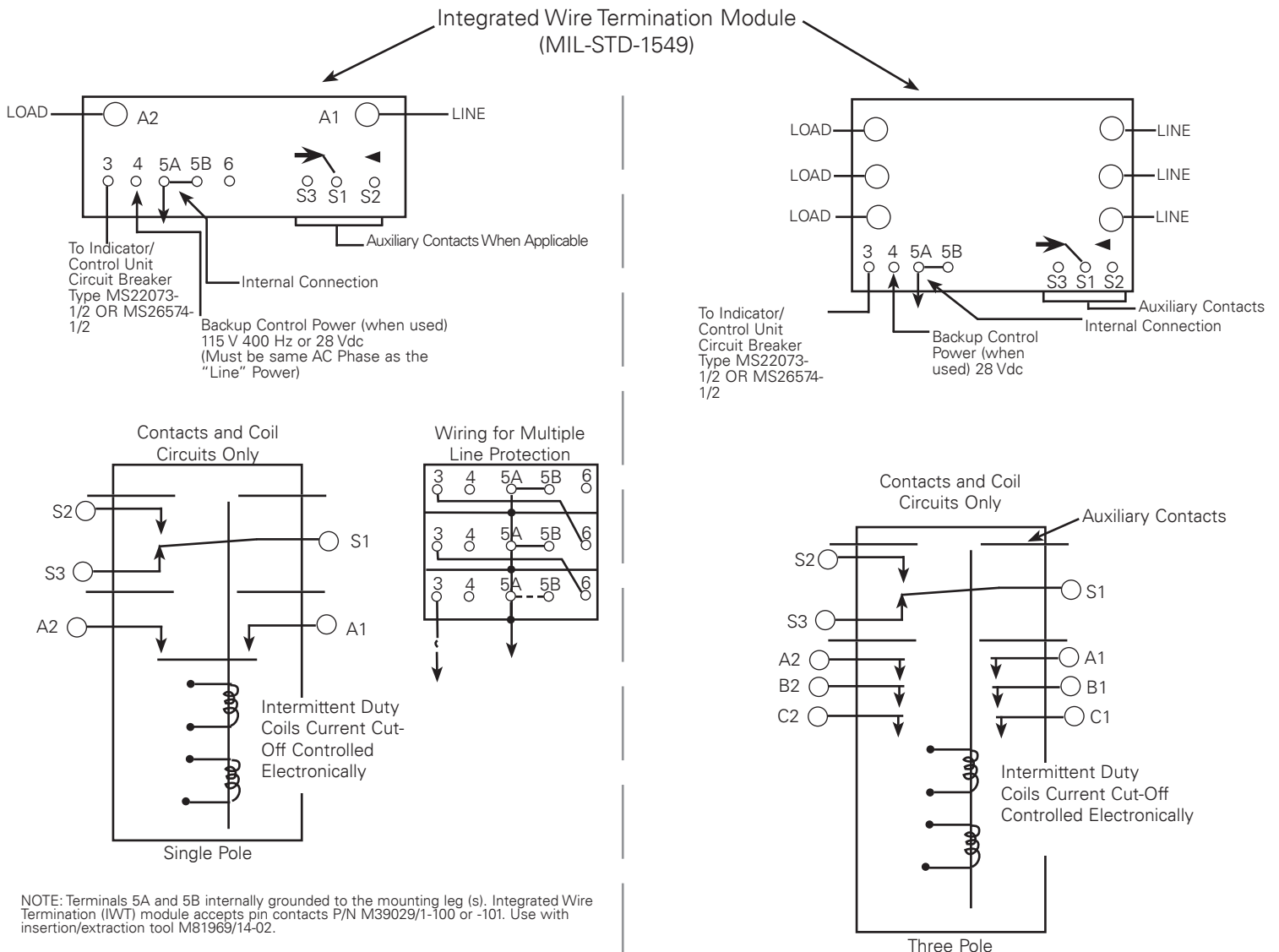

Engineering Data

Approximate Dimensions - 1 Pole

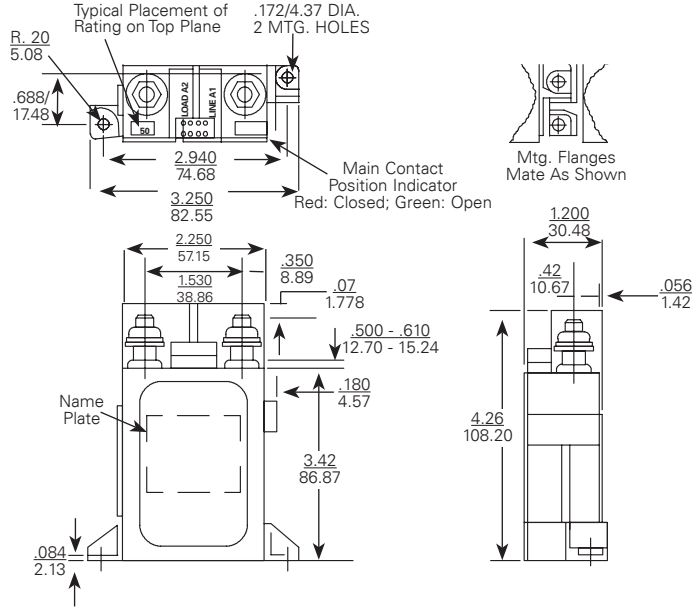

Options

- Special application auxiliary switches
- Unique grounding
- Power sources
- Other current ratings
- Control via systems other than I/CU
- Low level auxiliary contacts available
- Data Bus/Interface capability available
- Electronically held coil
- Moisture resistant sealing

Three Pole

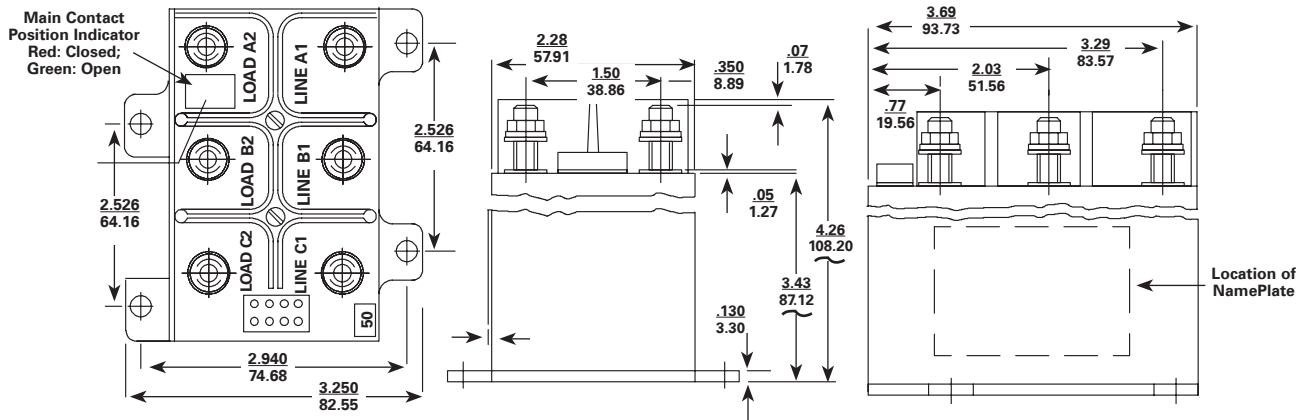

Coil Operate Current/Set And Trip Time RCCB

Circuits	Nominal System Voltage	I/CU Set Current @ Nom Voltage (Milliamp)	Set Coil Current @ Nom Voltage Pulse	MAX. Set Time		*I/CU. Trip Current Nominal					MAX. Standby Current Milliamp
				Nominal Voltage & Room Temp.	Most Adverse Condition - MIN. Voltage 71°C. Ambient	71°C & Nominal Voltage	-54°C & Nominal Voltage	Room Temp. Nominal Voltage	71°C & Nominal Voltage	-54°C & Nominal Voltage	
1 Pole	28 Vdc (18 volts MIN.)	2	3.0 AMP MAX	20 Millisec	35 Millisec	1.4 AMP	1.9 AMP	1.6 AMP	0.9 AMP ***	2.1 AMP	10
	115 Vac 400 Hz (104 V. MIN.)	2	10 AMP MAX	15 Millisec	30 Millisec	6.8 AMP **	6.3 AMP **	8.6 AMP **	6.1 AMP **	7.0 AMP **	10
3 Pole	28 Vdc (18 volts MIN.)	2	7.0 AMP MAX	20 Millisec	35 Millisec	1.5 AMP	2.0 AMP	1.7 AMP	0.9 AMP ***	2.2 AMP	10
	115 Vac 400 Hz (104 V. MIN.)	2	13.0 AMP MAX	15 Millisec	30 Millisec	4.3 AMP **	3.3 AMP **	4.5 AMP **	4.0 AMP **	3.1 AMP **	10

* MAX. I/CU. Line Impedance 75
** Average Half-Wave Rectified DC Current

Current Decreases w/Time so that I^2t
*** Absolute Min. Value from -54° to +71°C

REMOTE CONTROLLED CIRCUIT BREAKER (RCCB) — 1 POLE AND 3 POLE

Engineering Data

Description

The Remote Control Circuit Breakers (RCCB) concept, as load controllers in distributed-load applications, provides for a more efficient power distribution system with less line loss at a lower cost and with less weight than the conventional relay-flight deck circuit protector method.

Designed to meet the requirements of MIL-PRF-83383, the RCCB's capability and advantages include:

- Fusible link fail safe
- Remote on/off operation from the flight deck
- Visual indicators for open (green) and closed (red) on top surface
- Substantial reduction in weight and size
- Most direct route from power source to load
- Single wire control line from I/CU to RCCB
- Double-break power contact assembly
- Indication of trip or set by position of the ½ ampere circuit breaker on the flight deck
- Elimination of long runs of heavy and costly cables
- Magnetically latched coils (low power consumption)
- Use as a relay or circuit breaker or both
- Flanges mate for in-line or side-by-side mounting
- 1PST for DC or single phase AC
- 3PST for three phase AC only

Application

The Remote Control Circuit Breaker (RCCB) is a combination relay and circuit breaker which can be released or set by applying a release or set coil current electronically controlled

by a command from the Indicator/Control Unit (I/CU) (a ½ ampere fast trip, thermal circuit breaker).

With power available to terminal #4 and/or terminal A1 (28 Vdc or 115 V 400 Hz) on 1PST RCCB: to terminal #4 (28 Vdc) and/or both terminals B1 and C1 (115 V 400 Hz) on 3PST RCCB, the RCCB will assume the state requested/indicated by the I/CU. If power is removed from terminal #4 and A1 on 1PST or from terminal #4 and both B1 and C1 on 3PST, the RCCB will remain in the state it was in prior to power removal. When power is reapplied to the terminals, the RCCB will assume the state indicated by the I/CU.

With the RCCB closed, an overload or fault current on any line or lines will cause the RCCB to trip and in turn will cause a controlled overload of the I/CU, causing it to trip also. A fault or overload on any power contact will cause the RCCB to trip open within the time limits specified regardless of the availability of coil power. To reclose the RCCB, the I/CU line (line 3 to ground) must be opened by the I/CU or series switch and reconnected to ground.

Other Performance Parameters For MIL-PRF-83383

- Coordination. An overload applied to two devices in series with a 2 to 1 current rating will result in only the lower rated device opening.
- Rupture capability to 3600A (115 Vac rms or 28 Vdc for SM600BA and 115 Vac rms for SM601BA series)
- Dielectric. 1500 V, 60 Hz, MIL-STD-202, Test Method 301, 0.5 MA maximum



- Explosion-proof. MIL-STD-202, Test Method 109
- Thermal Temperature Range. -54°C to 71°C (-65°F to 160°F). MIL-STD-202, Test Method 107
- Insulation Resistance. MIL-STD-202, Test Method 302, 100 Megohms minimum
- Aircraft Electrical Power. MIL-STD-704
- Vibration. 10 g's to 2000 Hz. MIL-STD-202, Test Method 204. Condition C (-54°C, 25°C, and 71°C). Maximum duration of contact transfer to uncommanded state: 10×10^{-6} seconds.
- Shock. 25 g's. MIL-TD-202, Test Method 213. Maximum duration of contact transfer to uncommanded state: 10×10^{-6} seconds.
- Altitude. 50,000 feet
- EMI, MIL-STD-461, Class 1D
- Moisture Resistance. MIL-STD-202, Test Method 106
- Fungus Resistance. MIL-STD-454, Guideline 4
- Sand and Dust Resistance. MIL-STD-202, Test Method 110, Test Condition A
- Salt Spray Resistance. MIL-STD-202, Test Method 101, Test Condition B

Single Pole

- 28 VDC
- 115/200 VAC 400 Hz

Three Phase

- 115/200 VAC 400 Hz
- Three Phase Only

Qualified

Meets MIL-PRF-83383

Weight and Cost Savings

Saves fuel by eliminating long runs of heavy, costly cables

Space Savings

Keeps larger breakers out of cockpit

RCCB System for Remote Operation

To form an RCCB system enabling remote On/Off operation from the flight deck, combine the Safran Electrical & Power RCCB with Indicator Control Unit (ICU) model #1500-053-05 on pg. 13.

Single Wire from Flight Deck

Control of the RCCB requires only one #22 AWG control wire from the ICU on the flight deck to the RCCB.

Use as a Relay, Circuit Breaker, or Both

Combines the best attributes of a circuit breaker and a relay. Automatically protects the wires and the load device during circuit/load breakdown, but allows the flight deck control of the load during normal operation.

Design Concept

Introduction

Part of the weight of the modern jet aircraft comes from the electrical wires and power control systems needed to distribute the electrical energy. As these aircraft increase their passenger carrying capability, the electrical power management system becomes more complex and could become heavier. Wire runs of more than 300 feet from the flight deck circuit breakers to the load become common.

Utilization of Safran Electrical & Power's Remote Controlled Circuit Breakers (RCCB) close to the load or power source will eliminate much of these long, heavy, and expensive wire/cable. Control of the RCCB requires only one #22 AWG control wire from the flight deck to the RCCB.

Weight reduction, directly from wire use and indirectly from (generator) line heat loss, and installation and maintenance cost reductions becomes significant.

The RCCB combines the best attributes of a circuit breaker and a relay. The RCCB automatically protects the wires and the load device during circuit/load breakdown, but allows flight deck control of the load during normal operation.

Operation

The RCCB is basically a relay and a circuit breaker and allows the utilization of each identity singularly or in combination, depending upon the application. All of the RCCB's capabilities apply in either application.

It can be employed as a relay located adjacent to its load and remotely operated much like relays are today through control wiring and a switching device in the flight deck.

It can also be utilized as a circuit breaker and mounted adjacent to the load, the power source, or even the flight deck.

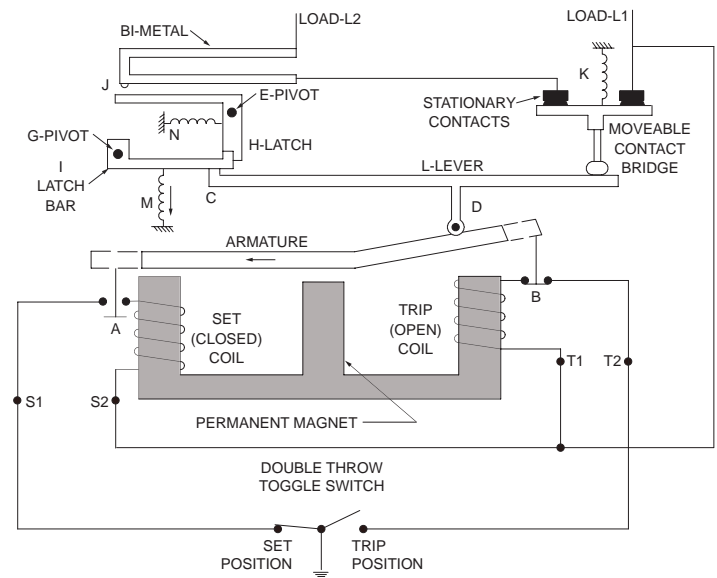

Figure 1

Single Pole RCCB

Motor Operation

Figure 1 depicts a simplified presentation of the RCCB.

Figure 2 describes the "motor", which when "energized", will result in typical armature transfer operation.

The magnetic circuit utilizes a permanent magnet as a fulcrum and latch for the rocking armature and uses electro-magnets (coils) at each end of the armature stroke for transfer purpose. In the set position (Figure 2), the flux generated by the permanent magnet follows a path from the top of the permanent magnet through the armature, through the left leg of the electro-magnet and back to the permanent magnet.

When the coil T1 -T2 is energized, the flux generated is such that it "flows" through the permanent magnet in the same direction as the flux generated by the permanent

magnet itself. Its path now, however, is through the right leg of the electro-magnet. The flux generated by the electro-magnet increases in magnitude as power is applied, and as the flux builds up in the path through the right leg of the electro-magnet, the flux tending to latch the armature in the left leg of the electro-magnet becomes very small in comparison. The armature then "transfers" and seals at the pole face of the right leg of the electro-magnet.

The cutthroat contact B in series with coil T1 -T2 is opened by mechanical actuation due to the armature movement. In Figure 2, a "dotted extension" of the armature represents the mechanical actuator of the cutthroat contacts. In actual design, this is accomplished more conveniently through only one armature extension and an appropriate actuator which drives both contacts B and A.

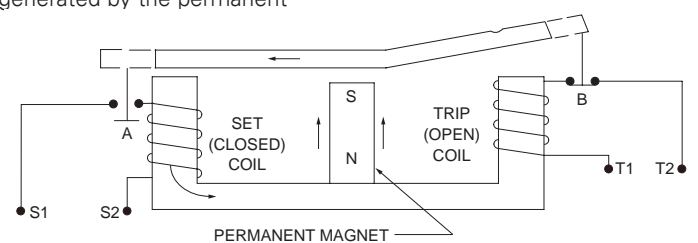

Figure 2

The opening of contact B occurs in the last several thousandths of an inch travel of the armature movement. After coil opening, the armature movement continues (until it seats i.e. seals), due in some degree to the inertia of the armature, but mostly due to the magneto-motive force of the permanent magnet in conjunction with the decreasing air gap at the right pole face.

The device now is again in a stable position, but the armature has transferred and the following conditions exist:

Contact A is closed and contact B is open, and the armature is sealed and latched at the right leg of the electro-magnet. To transfer the armature to its original position, energizing the coil S1-S 2 allows the process described above to occur in the opposite direction.

There are a number of advantages to this design approach of the "motor."

1. The coils open upon transfer of the armature; hence, the actual "on time" or duty cycle approximately equals the operate time of the relay. Accordingly, the coil can be driven hard without fear of burnout. The "hot coil" with the low timer constant results, in turn, in fast operate times.
2. Using intermittent duty coils (smaller coils with less copper) results in less weight and smaller sizes.
3. Power is conserved. This is important for two reasons. If a relay is to use power, it must be available. In some of the present day and future vehicles, power remains an expensive commodity, and elimination of coil power drawing (10-35 watts) in power devices can add up

especially when vehicles sophistication requires use of a significant number of these devices. Also, it must be remembered that power utilized by relay coils generate heat which must be dissipated. The necessary elimination of this heat, in turn, requires the use of additional energy from the main power source.

4. As indicated, the cutthroat contacts are opened by the armature mechanically during the last several thousandths of an inch travel of armature movement. Note: In actual RCCB, the cutthroat contacts function is replaced by electronic control of coil on time.

RCCB Operation As A Relay

To examine the RCCB operation as a relay, refer to **Figure 3** and **4**. The device is shown in the set position in **Figure 3** and in the tripped position in **Figure 4**. The circuit path is from L2, through the bimetal to one of the stationary contacts. L1 is connected directly to the other stationary contact.

The movable bridge closes the circuit by bridging between the two stationary contacts.

As can be seen, movement of the armature about its fulcrum will determine the position of the contacts. When coil S1-S 2 has been energized such that the armature seals on the left-hand pole face (**Figure 3**), the mechanical linkage system closes the contacts. Conversely, when coil T1-T 2 has been energized, such that the armature seals on the right-hand pole face (**Figure 4**), the relay contacts will open due to the spring forces exerted by compression spring K.

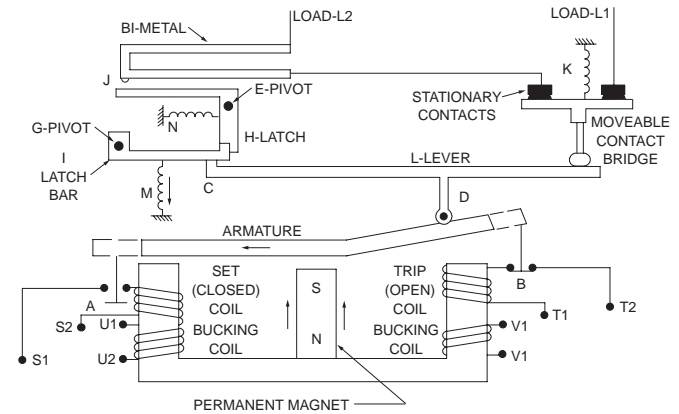

Figure 3

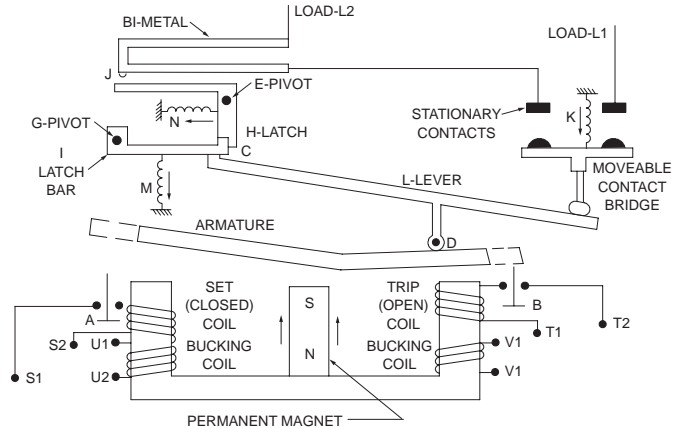

Figure 4

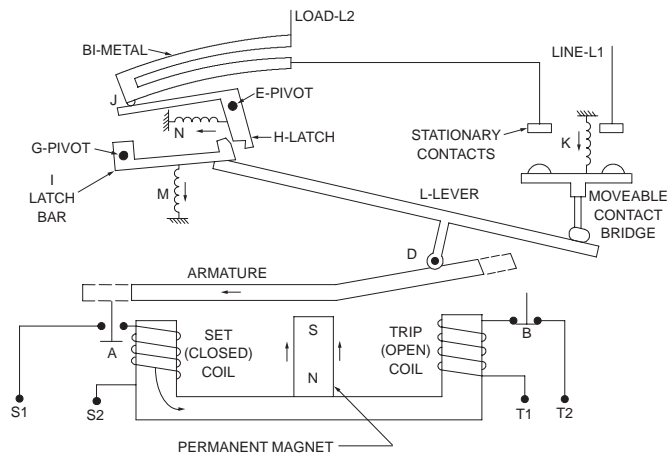

Figure 5

Note: there is an "upward force" directed on the lever L through the linkage tying into the armature at point D. During operation as a relay, point C (interface between lever L and latch bar I) is "fixed" in place, and the lever L actually rotates about point C when moving the contact structure from the opening to the closed, and from the closed to the open position.

Note that the coil U1-U2 is connected in parallel with T1-T2. It is wound on the left-hand core of the electro-magnet such that when energized along with T1-T2, the force it generates will be in a direction opposing the latching force generated in that core by the permanent magnet.

The utilization of a permanent magnet and intermittent duty coils, in conjunction with cutthroat contacts, allows a considerable reduction in copper and iron from that normally required in electro-magnets for continuous duty operation.

RCCB Operation as a Circuit Breaker

To examine the operation of the device as a breaker, refer to **Figures 3, 4, and 5**.

In **Figure 3**, the device is shown in the closed contact position (presumably) carrying rated current. Should an overload occur, currents greater than rated currents now "flow" through the device "entering" through L2, passing through the bimetal, through the connection of the bimetal to one stationary contact, through the bridging moveable contact structure, to the other stationary contact, and "out" through L1.

Depending upon the size of the overload, the bimetal will begin to deflect as shown in **Figure 5** until the actuating end of the bimetal engages latch H at point J.

Motion and force due to the deflection of the bimetal moves latch H such that it rotates in a counter-clockwise direction around its pivot point E.

When latch H has moved an adequate distance, the upward force of lever L, applied at point C to latch bar I, will rotate latch

bar I counter-clockwise around its pivot point G. This allows the main lever L to rotate clockwise around point D (where it is engaged with the armature) due to the "contact return" spring (compression spring) force K acting upon the moveable contact bridge.

Note that when this overload occurs, the armature is not transferred to the "off" (tripped) position, but instead remains in the latched position normally associated with the "on" (set) position of the device.

To "reset" the device after the fault or overload clears could be readily accomplished by energizing the "trip" coil (T1-T2) through a toggle or push-button switch (see **Figure 1**) located in the flight deck. The armature would then transfer and seal on the right-hand core of the electro-magnet, which is the "open" position shown in **Figure 4**. At that time, springs M and N (tension springs) would reposition latch bar I and latch H to the position shown in **Figure 4**, providing that the bimetal has now cooled sufficiently and returned to its original position as shown in **Figure 4**. At this stage, the RCCB is still in an "open position" i.e. (the contacts are open), but as outlined above, the fault or overload has been cleared through action and operation of the device through bimetallic activity, i.e. "Circuit Breaker" operation.

To re-close the contacts, it is now only necessary to energize coils S1-S2 and re-establish a mechanism position similar to that shown in **Figure 3**. If the fault of overload condition is still in existence, the device would again trip through bimetallic activity as just described.

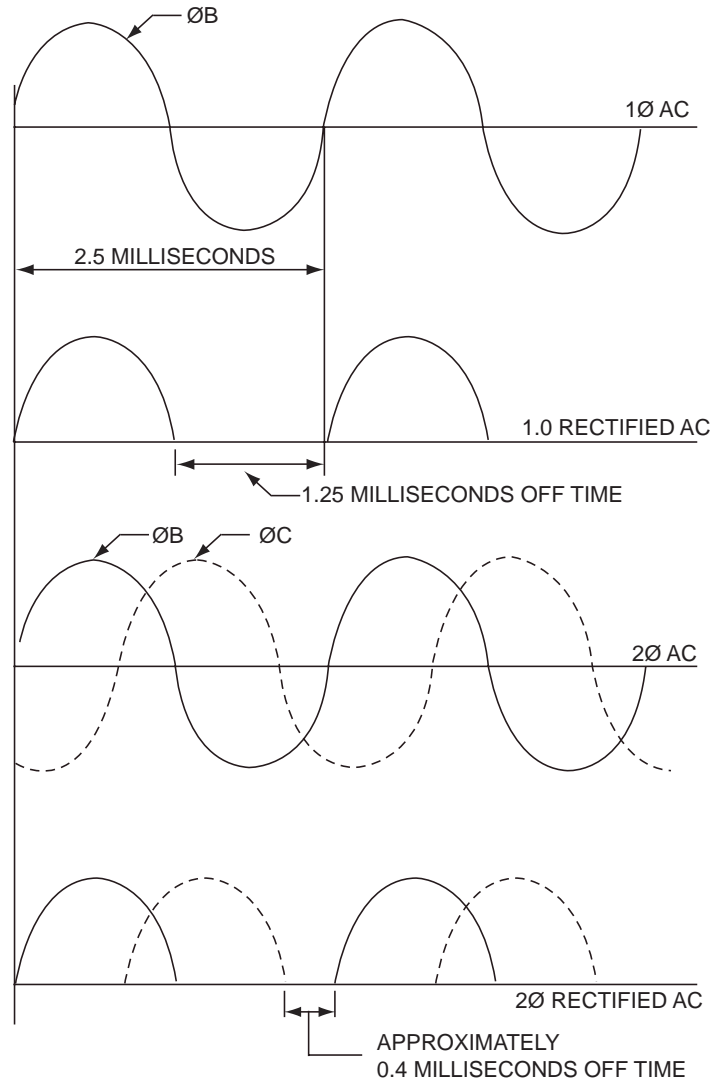

Figure 6

Three Pole RCCB

The design principles employed in the 3-pole RCCB have followed many of the same paths utilized in the 1-pole RCCB. Differences other than the obvious, such as size, weight, shape, etc., are explained below.

Motor Operation

The principles of motor operation and construction of the three pole devices are similar to those employed in the single pole RCCB. In the 3-pole device, the AC operating power is drawn from two of the three

phases. The "off" time between current pulses during coil energization is approximately 0.4 milliseconds. In comparison, the "off" time for single-phase power is approximately 1.25 milliseconds. See **Figure 6**.

The timing circuit establishes a coil "on" time longer than the actual transfer time of the armature. The operation of the 3-pole RCCB is identical to the 1-pole.

Control Circuit

Refer to **Figure 7**. There is one minor difference in operating principles and parameters from

the single pole devices.

The difference is the addition of a power junction area in the electronics. (see **Figure 7**).

The 3-pole RCCB is designed for use in 3-phase circuits and is a 400 Hz AC load controller. The power junction is designed to use AC power only. DC operate (coil) power may be used even though AC loads are to be controlled. This connection is made at terminal 4 of the IWTS connector. In **Figure 7**, two separate power junctions are shown: one for AC and one for DC. In the event both AC and DC are connected to the RCCB, only AC would be utilized by the

logic circuit. Should AC power be lost, the DC connection would automatically take over the control function.

The other differences between 1-phase and 3-phase control circuitry, i.e. timer addition, is directly related as described in the above Motor Operation section.

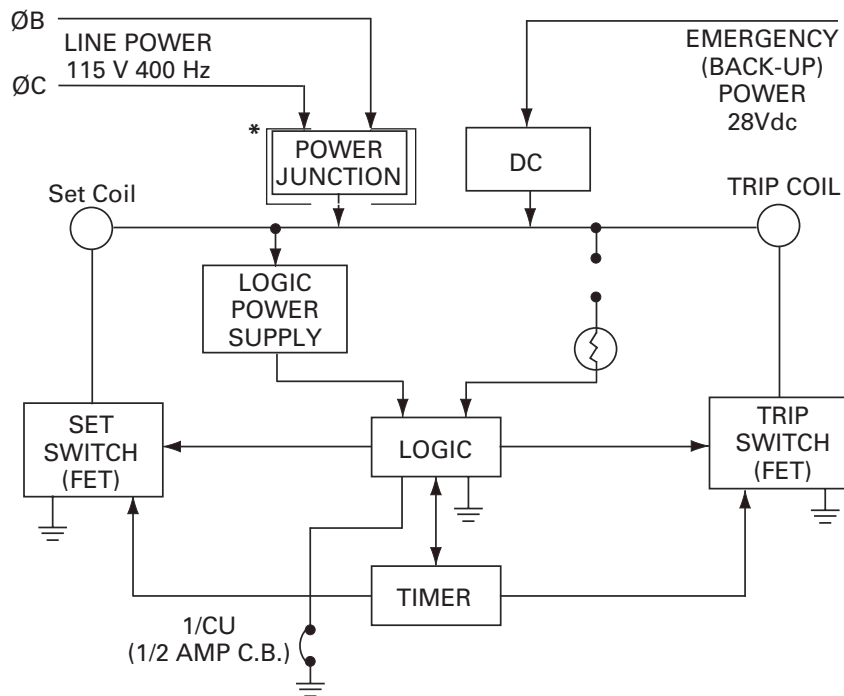

Figure 7

*Indicates In 3 Phase Electronics



Single Pole
• 28 VDC

Electronic Current Sensing

The electronic over current sensing of these devices offer several advantages over the bi-metal sensing RCCB. Trip current levels can be closely controlled, for better protection of sensitive loads, trip times are faster, and both can be customized for specific applications. Other advantages included less heat buildup, and higher current capabilities in the same small package.

Use as a Relay, Circuit Breaker, Or Both

RPCs, like RCCBs, combine the best attributes of a circuit breaker and a relay. Automatically protects the wires and the load device during circuit/load breakdown, but allows the flight deck control of the load during normal operation.

Weight and Cost Savings

In distributed-load applications, RPCs are a more efficient power distribution solution promoting cost and weight savings through the elimination of long runs of heavy cables associated with the conventional relay - flight deck circuit protector method. Control of the RPC requires only one #22 AWG control wire from the ICU (model #1500-053-05) on the flight deck to the RPC.

PERFORMANCE DATA

Rupture Levels	2500 A (28VDC)
Endurance (Resistive)	50,000 Cycles
Endurance (Inductive and Motor)	25,000 cycles
Endurance (Lamp)	No Rating
Mechanical Life	100,000 cycles
Dielectric Strength	Sea Level - VRMS .2-3 seconds: Coil to Case - 1250 initial, 1,000 After Life, All other Points 1,800 Initial, 1350 After Life 50,000 ft - VRMS 1 Minute: Coil to Case 500 Initial & After Life. All other Points 700 Initial & After Life
Insulation Resistance	1100 Megaohms initial, 50 Megohms after Life, MIL-STD-202, method 302, test condition B
Thermal Temperature Range	-55°C to 85°C (-67°F to 185°F).
Vibration	Sinusoidal 5 to 10 Hz: 0.08 DA; 10 TO 55 Hz: 0.06 DA; 55 to 2000 Hz: 10G's
Shock	50G's. (1/2 sine, 10-12 ms)
Altitude	50,000 ft. Maximum
EMI Requirements	MIL-STD-461, Requirements CS114 and RE102 over the frequency range of 14 kHz to 400 MHz and RE102 limits for Aircraft and Space Systems
Moisture Resistance	MIL-STD-202, method 106
Salt Spray Resistance	MIL-STD-202, method 101, Condition B
Sand and Dust Resistance	MIL-STD-202, method 110, Condition A
Fungus Resistance	MIL-HDBK-454, Guideline 4
Explosion Proof	MIL-STD-202, method 109
Weight (Standard)	425.017 grams (0.937 lbs.)

OVERLOAD DATA

% Rated Current	Trip in Seconds -55°C to +85°C
100%	No Trip
125%	45 Sec. Trip
200%	0.22 Sec. Trip
400%	0.095 Sec. Trip

ORDERING INFORMATION

Single Pole Single Throw (Double Break Contacts)

AMPERE RATING	Safran Electrical & Power P/N	Rated Contact Load (Amperes) 28VDC			
		Res.	Ind.	Motor	Min.
125	SM600BA125A1	125	125	125	5
150	SM600BA150A1	150	150	150	5
175	SM600BA175A1	175	150	175	5
200	SM600BA200A1	200	150	175	5

Notes:

- One auxiliary contact included on each unit
- Contact Business Unit on Alternate Amperages, Trip Times, Control Configurations, Grounding, Auxiliary Switches, Mounting Systems, etc.

Typical Characteristics

Specifications

- Design to meet the general requirements of MIL-R-6106 Type II continuous Duty Unsealed
- Contacts are covered & gasketed
- Double break contacts
- All units are thermal breaker compatible at rated relay resistive load
- Some models available with auxiliary circuits
- Gold-plated auxiliary contacts for low-level applications available
- Auxiliary contacts ratings:
 28 Vdc: 5 amps resistive
 3 amps inductive
 2.5 amps lamp

Ratings Per MIL-R-6106:

- Salt spray, humidity, acceleration, sand & dust, intermediate current
- Vibration:
 5 to 10 Hz -.08 DA
 10 to 55 Hz -.05 DA
 55 to 500 Hz -2.0 g's
- Shock: 25 g's (6-9 MS ½ sine wave)
- Life: (-55 to 71°C)
 50,000 cycles electrical at full rated load
 100,000 cycles mechanical tested at 25% rated load
- Altitude: 50,000 feet

Part Number	Rated Contact Load				Rupture Current	Contact Rating			
	28 Vdc					Intermittent Power			
	Res.	Ind.	Motor	Intermediate		28 Vdc			
						15 Minute	5 Minute	1 Minute	Max. Inrush
SM100D2	100	80	100	4	1000	130	150	200	600
SM100D3	100	80	100	4	1000	130	150	200	600
SM150D1	150 ^⑤	50	150 ^①	15	1200	195	225	300	900
SM150D2	150 ^⑤	50	150 ^①	15	1200	195	225	300	900
SM150D3	150 ^⑤	50	150 ^①	15	1200	195	225	300	900
SM150D4	150 ^⑤	50	150 ^①	15	1200	195	225	300	900
SM150D5 ^③	150	50	150 ^①	15	1200	195	225	300	900
SM200D1	200	100	200	20	2000	260	300	400	1200
SM200D2	200	100	200	20	2000	260	300	400	1200
SM200D3	200	100	200	20	2000	260	300	400	1200
SM400D1	400	100	400	40	4000	520	600	800	2400
SM400D2	400	100	400	40	4000	520	600	800	2400
SM400D3	400	100	400	40	4000	520	600	800	2400
SM1000D11 ^④	1000	—	—	50	6000	1200	1500	2000	2500 ^⑥

- ① 600 Amp make, 200 Amp break
- ② Duty cycle: 1 minute on, 1 minute off; 1 minute on, 20 minutes off
- ③ Maximum vibration 2000 Hz 2 g's
- ④ Duty cycle: 1.5 minutes on, 3 minutes off
- ⑤ Will carry 200 Amps at 20% on duty cycle per minute
- ⑥ Maximum inrush provided coil voltage as noted is maintained
- ⑦ Operate time at 28 Vdc & 25 deg. C.
- ⑧ Contact bounce is average of 5 consecutive ratings.
- ⑨ Available in normal closed circuit.
- ⑩ 1 sec. on, 60 sec. off

Circuit Diagrams

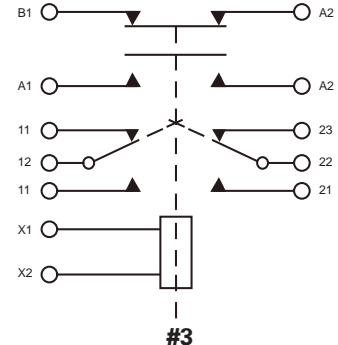
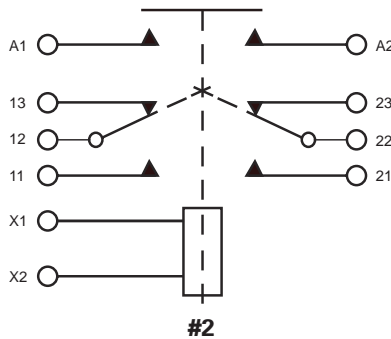
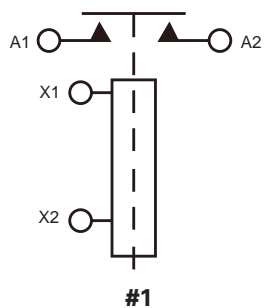

Typical Characteristics

(Figures 1 through 8)
 (For additional details, contact your local Safran Electrical & Power Technical Sales Representative)

- Power Contact Voltage Drop:
 Initial 0.15 V After Life Test: 0.175 V
- Insulation Resistance: Initial 200 Meg ohm.
 After Life Test: 100 Meg ohm
- Dielectric Withstanding Voltage: **50,000 Feet 60 Seconds**
 Initial & After Life Test: 500 V
- **2.5 Seconds Sea Level**
 Initial: 1250 V
 After Life Test: 1000 V
 Power Contacts: 650 V

POWER RELAYS — GASKET SEALED - 100 AMPS TO 1,000 AMPS

Contact Transfer Milliseconds, Max.							Coil Data						
Op. ⑥ Time	Rel. Time	Contact Bounce ⑥	Poles & Throw	Weight Lbs./gm	Circuit Dia.	Dimension Fig.	Res. (OHMS)	Max. Volts Pick Up	Max Volts- Drop Out	Duty Cycle	Mounting	Auxiliary Termination	Part Number
35	15	6	SPST/NO	0.6/272	1	1	94.2	18	7 to 1.5	Cont	Side	—	SM100D2
35	15	6	SPST/NO	0.6/272	1	2	94.2	18	7 to 1.5	Cont	Top	—	SM100D3
40	15	5	SPST/NO	0.95/430	2	3	82.7	16.5	1 to 7	Cont	B	Screw	SM150D1
40	15	5	SPST/NO	0.95/430	2	3	82.7	16.5	1 to 7	Cont	B	IWTS	SM150D2
15	12	5	SPDT	1.25/567	3	4	6.6	6.5	0.2 to 3	Inter ^②	B	Screw	SM150D3
15	12	5	SPDT	1.25/567	3	4	6.6	6.5	0.2 to 3	Inter ^②	B	IWTS	SM150D4
40	15	5	SPDT	1.25/567	3	4	60	18	0.6 to 8.5	Cont	B	Screw	SM150D5
25	10	2.5	SPST/NO	1.3/588	2	5	66	18	1.5 to 7	Cont	Side	Lug	SM200D1
25	10	2.5	SPST/NO	1.3/588	2	6	66	18	1.5 to 7	Cont	B	Lug	SM200D2
25	18	5	SPST/NO	1.3/588	2	6	10	7.5	0.5 to 3	Inter ^④	B	Lug	SM200D3
40	15	10	SPST/NO	2.6/1177	2	7	60	18	1.5 to 7	Cont	Side	Lug	SM400D1
40	15	10	SPST/NO	2.6/1177	2	8	60	18	1.5 to 7	Cont	B	Lug	SM400D2
20	15	10	SPST/NO	2.6/1177	2	8	10	7.0	0.5 to 3	Inter ^④	B	Lug	SM400D3
60	30	3	SPST/NO	4/1810	1	9	38	18	1 to 7	Cont	Side	—	SM1000D11

① 600 Amp make, 200 Amp break

② Duty cycle: 1 minute on, 1 minute off; 1 minute on, 20 minutes off

③ Maximum vibration 2000 Hz 2 g's

④ Duty cycle: 1.5 minutes on, 3 minutes off

⑤ Will carry 200 Amps at 20% on duty cycle per minute

⑥ Maximum inrush provided coil voltage as noted is maintained

⑦ Operate time at 28 Vdc & 25 deg. C.

⑧ Contact bounce is average of 5 consecutive ratings.

⑨ Available in normal closed circuit.

Dimensions (See next page for other dimension figures)

Figure 9

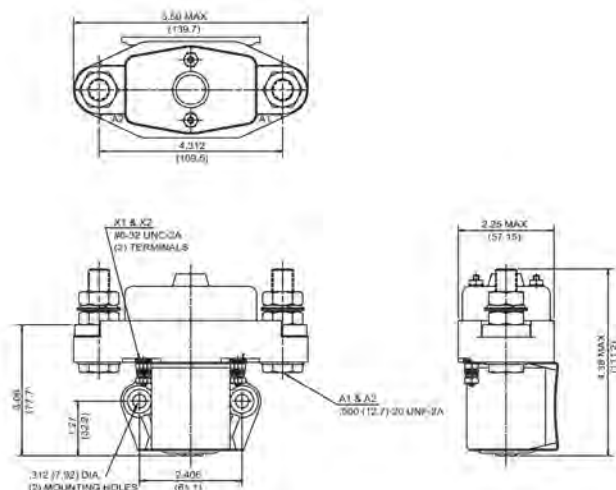

Insulation Resistance:

Initial: 100 Meg ohms
After Life Test: 50 Meg ohms

Dielectric Withstanding Voltage:

(2.5 Seconds Sea Level)
Initial: 1250 V
After Life Test: 1000 V



Unit Shown Without Auxiliary Contacts

Life at 1000 Amps limited to 10,000 cycles. Life at 50 Amps is 50,000 cycles minimum. Rupture life is 20 cycles at 6000 Amps. This unit is available with inverted terminals, bottom mounting, available with normally closed power contacts, and DPDT auxiliary circuits.

Dimension Figures

Figure 1

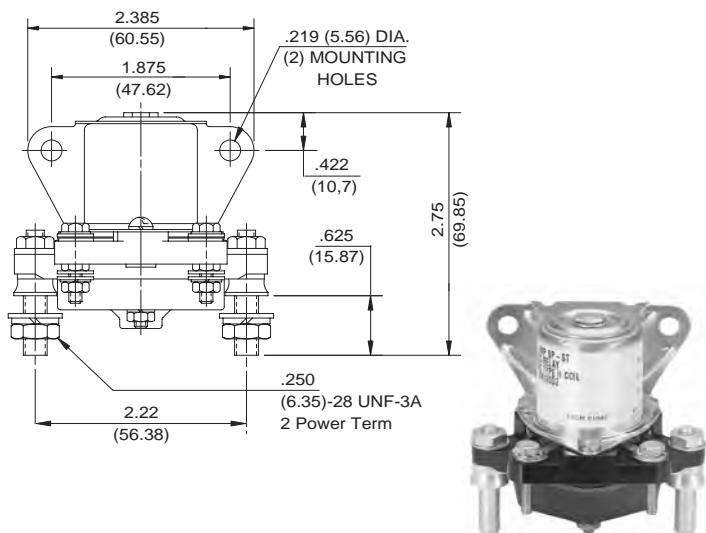

Unit Shown Without Auxiliary Contacts

SM100D2

Figure 2

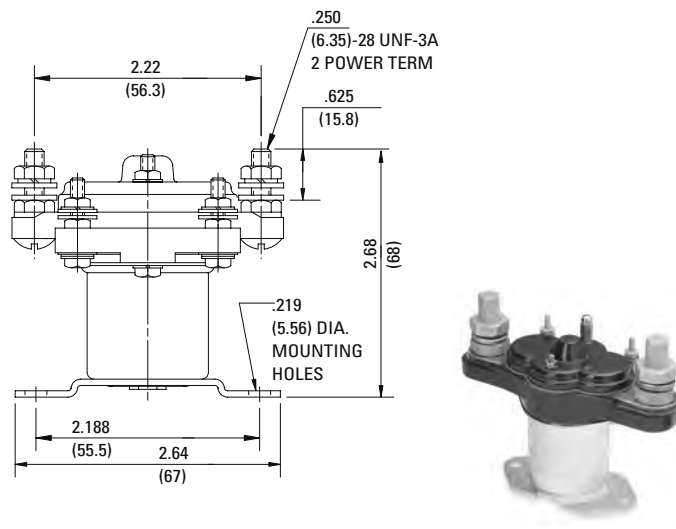

Unit Shown Without Auxiliary Contacts

SM100D3

Figure 3

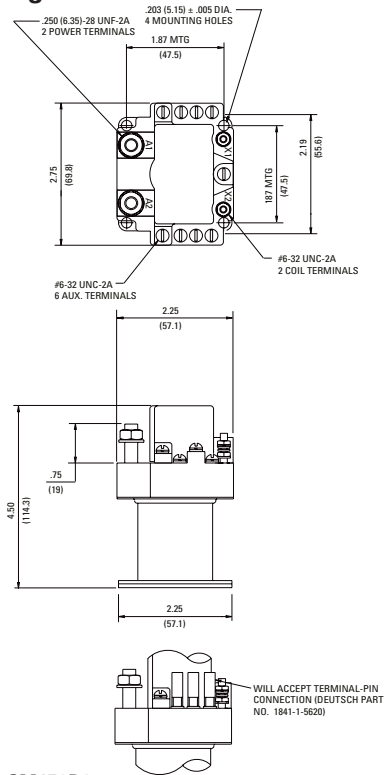

SM150D2

Figure 4

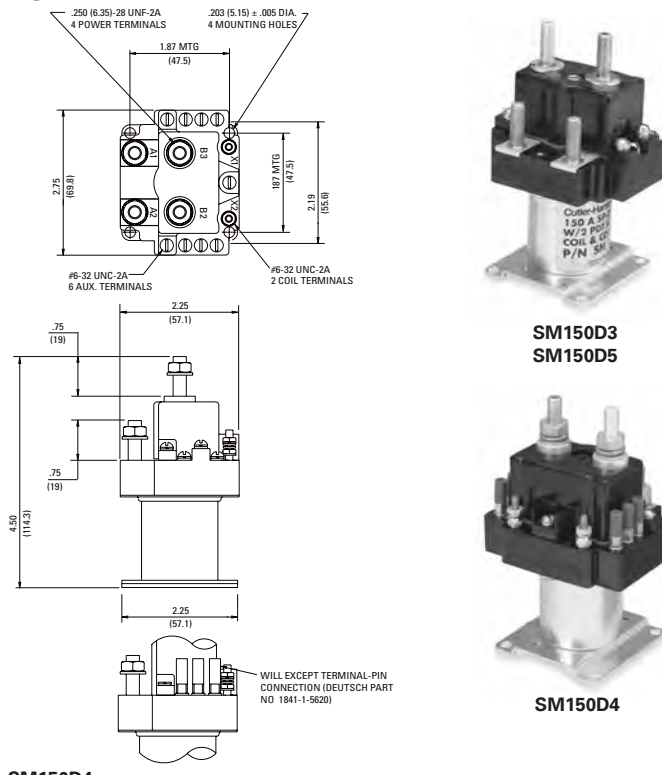

SM150D4



SM150D1



SM150D2

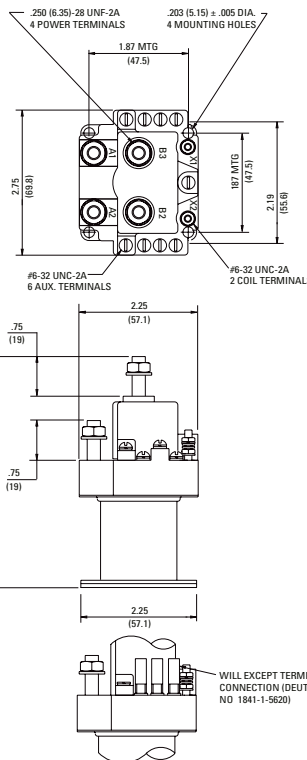

SM150D3
SM150D5



SM150D4

Dimension Figures

Figure 5

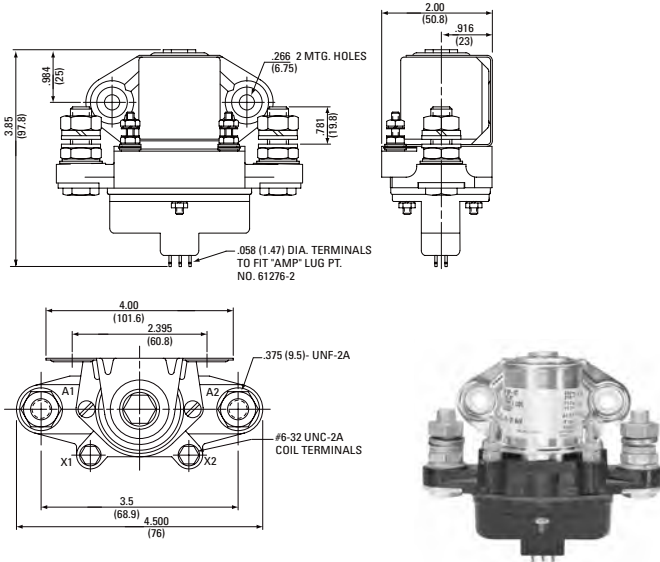

SM200D1

Figure 6

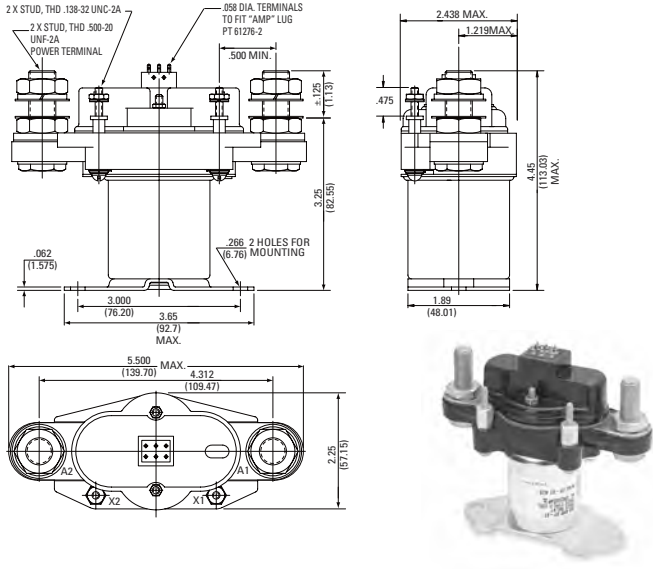

SM200D2
SM200D3

Figure 7

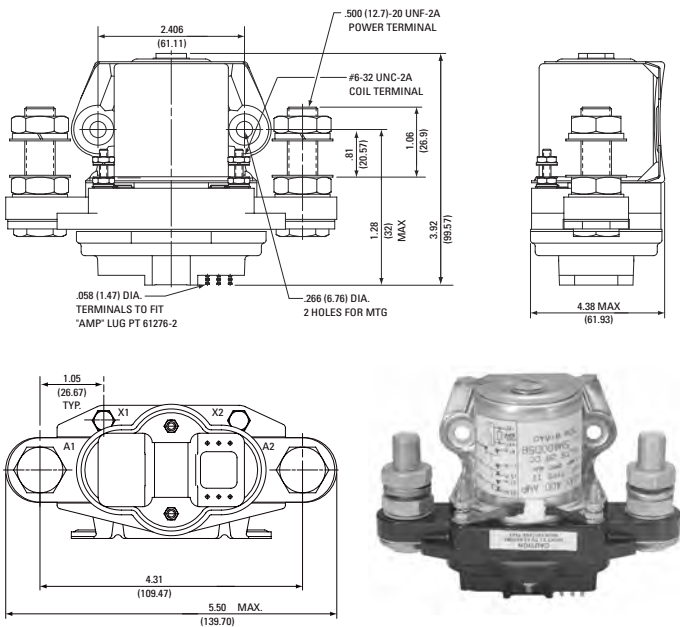

SM400D1

Figure 8

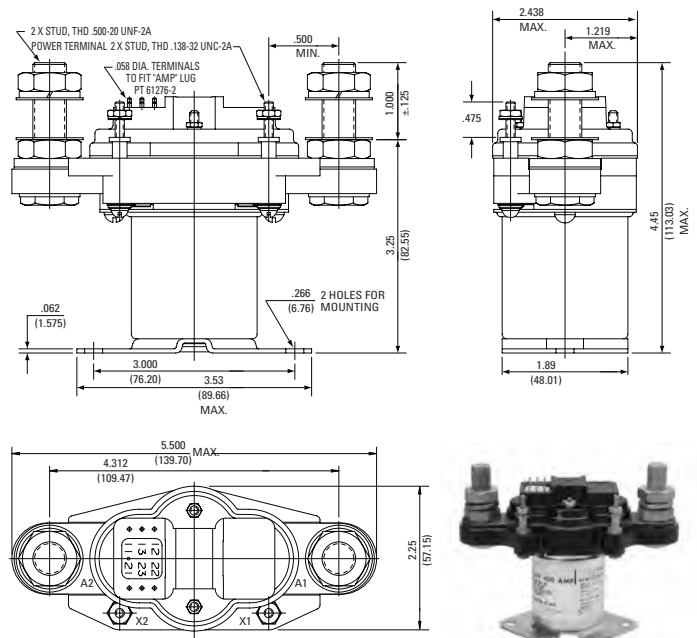

SM400D2
SM400D3

General Specifications

- Designed to MIL-R-6106
 - Type II Unsealed Continuous Duty
 - Type III Unsealed Intermittent Duty
 - Covered/Gasketed Contact Area
 - Twin-break Silver Alloy Contacts
- Meets Explosion, Humidit, Salt, Spray, Sand, and Dust requirements.
- Altitude: 50,000 feet
- Shock: 25 g's ½ Sine 6 to 9 milliseconds
 - Maximum contact opening: 2 milliseconds
- Acceleration: 10 g's
- Vibration Limits:
 - 5 to 10 Hz: 0.8 in DA
 - 10 to 55 Hz: 0.6 in DA
 - 55 to 2000 Hz: 2 g's
- Temperature Range: -55°C to 71°C
- Insulation Resistance:
 - 100 megohm minimum initially
 - 50 megohm minimum after tests
- Dielectric:
 - 1250 Vac minimum initially
 - 1000 Vac minimum after tests
- Life:
 - Electrical Operations: 50,000 cycles
 - Mechanical Operations at 25% of Rated Resistive Load: 100,000 cycles
- Minimum Current: 10% of Rated DC Resistive Load
- Intermittent Duty Ratings:
 - % of Rated Resistive
 - Time On in Minutes
 - Cooling time is required between successive over load applications.

Intermittent Duty Ratings

Minutes			
15	5	1	Inrush
130%	150%	200%	600%
Rupture Time Per MIL-R-6106			

(Coil Voltage must be maintained at rated value)

- Options:
 - Other Coil Voltage
 - Alternate Mountings
- MIL-STD-461 applies to AC operated coils.
- See drawing for additional applicable details.

Special Service Use

Mechanical Interlock/Type Service

Part Number	Reversing	Transfer	Dynamic Braking
9565H29	X	X	—
6046H39	X	—	X
6046H46	X	X	—
6046H53	X	X	—



Cat N. 6041H217

- SPST rated 400 Amp resistive and motor at 28 Vdc continuous duty with top mounting.
- MS24185-D1 - 2.6 Lbs/ 1179gm



Cat N. 6041H202

- SPST rated 200 Amp resistive and motor at 28 Vdc continuous duty with side mounting.
- MS24171-D2 - 1.25 Lbs/ 567gm



Cat N. 6041H209

- 2 PST rated 100 Amp resistive at 28 Vdc and 75 amperes 115/200 V 400 Hz intermittent duty with top mounting.
- AN-3392-1 - 1.5 Lbs/ 680 gm



Cat N. 6041H201

- SPST rated 50 Amp resistive, inductive and motor at 28 Vdc continuous duty with side mounting.
- MS24166-D2 - 0.5 Lbs/ 225 gm



Cat N. 9565H2

- 3 PST rated 25 Amp resistive, inductive and motor at 28 Vdc and 115/200 V 400 Hz continuous duty cycle with base mounting.
- MS24192-D1 - 1.1 Lbs/ 499 gm

Reversing and Dynamic Braking Relay



Cat N. 6046H39

- Control of split field series motors.
- SPST see circuit diagram 6 for details.
- Rated 28 Vdc 50 Amp N.O., 25 Amp N.C
- 2.9 Lbs./1315 gm

POWER RELAYS — CONTINUOUS DUTY, TYPE II, UNSEALED INTERMITTENT DUTY, TYPE III, UNSEALED

Safran Electrical & Power Part Number	Government Part Number	Continuous Power Contacts, Ratings						Contacts Operate Milliseconds, Maximum				Coil Data							
		28VDC			115/200 VAC 400 Hz.			OP TIME	REL TIME	Contact Bounce	Poles & Throw ^③	Weight Lbs./GMS	Circuit Dia./ Dim. Figure	Resistance (OHMS)± 10% Pickup/ Sealed	Volts Pickup ^⑤	Volts Drop-out ^⑥	Duty Cycle	Mounting	Coil Voltage Nominal
		RES.	IND.	MOTOR	RES.	IND.	MOTOR												
9565H2	MS24192-D1	25	25	25	25	25	25	20	15	6	3PST	1.1/498	10 / 11	/ 60	18	1.5 to 7	CONT	BASE	28 dc
9565H29	MS24152-D1	25	25	25	25	25	25	20	15	6	3PDT	2/909.09	16 / 11	22 / 92	18	1.5 to 7	CONT	BASE	28 dc
9565H95	—	25	25	25	25	25	25	20	15	6	3PST	1.06/482.95	10 / 11	/ 1160	70	8 to 38	CONT	BASE	120 dc
6041H53 ^②	—	50/25	50/25	50/25	25/25	—	—	20	15	5 N.O./10 N.C.	SPDT	.54/245.45	4 / 2	16.9	8.2	0.8 to 4.8	CONT	TOP	12 dc
6041H220 ^②	MS24187-D1	50/25	50/25	50/25	25/25	—	—	20	15	5 N.O./10 N.C.	SPDT	.54/245.45	4 / 2	94.2	18	1.5 to 9	CONT	TOP	28 dc
6041H230	MS24187-D2	50/25	50/25	50/25	25/25	—	—	20	15	5 N.O./10 N.C.	SPDT	.54/245.45	4 / 2	94.2	18	1.5 to 9	CONT	TOP	29 dc
6046H39 ^②	—	50/25	50/25	50/25	—	—	—	—	—	—	SPDT	2.9/1318.18	6 / 7	26	18	7	—	TOP	28 dc
6041H201	MS24166-D2	50	50	50	—	—	—	20	10	5	SPST	.50/225	1 / 4	94.2	18	1.5 to 7	CONT	SIDE	28 dc
6041H149	—	50	50	50	—	—	—	20	15	5	SPST	.56/254.55	1 / 4	16.9	8.2	0.8 to 4.8	CONT	SIDE	12 dc
6041H200	MS24166-D1	50	50	50	—	—	—	20	10	5	SPST	.50/225	1 / 4	94.2	18	1.5 to 7	CONT	TOP	28 dc
9565H94	MS24193-D1	50	50	50	50	50	50	20	15	4	3PST	1.51/685	10 / 11	13.5 / 71.5	18	1.5 to 7	CONT	BASE	28 dc
6041H219	MS24178-D1	55	40	40	55	—	35	—	—	—	DPST	.75/340.91	2 / 2	66	18	1.5 to 7	Note ^④	TOP	28 dc
6041H80	—	100	80	80	—	—	—	—	—	—	SPST	1.4/636.36	1 / 3	66.3	18	1.5 to 7	CONT	SIDE	28 dc
6041H144	—	100	80	80	—	—	—	—	—	—	SPST	1.4/636.36	1 / 3	66.3	18	1.5 to 7	CONT	SIDE	28 dc
6041H11	—	100	80	80	—	—	—	—	—	—	SPST	1.4/636.36	1 / 1	66.3	18	1.5 to 7	CONT	TOP	28 dc
6041H209	AN3362-1	100	80	80	75	—	65	35	10	3.5	DPST	1.5/685	2 / 2	43	20	1.5 to 7	Note ^④	TOP	28 dc
6046H53	MS25031-D1B	100	80	80	75	—	65	—	—	—	DPDT	3.5/1590.91	9 / 7	43	18	1.5 to 7	CONT	TOP	28 dc
9565H13	—	100	75	75	100	—	75	22	15	4	3PST	2.5/1136.36	12 / 11	9 / 53	18	1.5 to 7	CONT	BASE	28 dc
6041H202	MS24171-D2	200	100	200	—	—	—	25	10	50	SPST	1.25/568.18	1 / 5	66	18	1.5 to 7	CONT	SIDE	28 dc
6041H105	—	200	100	200	—	—	—	—	—	—	SPST	1.25/868.18	1 / 5	10 (+15/-10)	9	3.5	CONT	SIDE	12 dc
6041H123	—	200	100	200	—	—	—	40	15	5	SPST	1.3/590.91	1 / 5	66	18	1.5 to 7	CONT	SIDE	28 dc
6041H203	MS24172-D2	200	100	200	—	—	—	25	18	5	SPST	1.23/560	1 / 5	10 (+15/-10)	7.5	0.5 to 3.0	INTER ^③	SIDE	28 dc
6041H212	—	200	100	200	—	—	—	40	15	5	SPST	1.3/590.91	1 / 5	66	18	1.5 to 7	CONT	SIDE	28 dc
6041H215	MS24171-D1	200	100	200	—	—	—	25	10	5	SPST	1.33/604.55	1 / 1	66	18	1.5 to 7	CONT	TOP	28 dc
6041H216	MS24172-D1	200	100	200	—	—	—	25	10	5	SPST	1.33/604.55	1 / 1	10(+15/-10)	7.5	0.5 to 3.0	INTER ^③	TOP	28 dc
6046H46	MS25032-D1	200	100	150	150	—	100	40	15	5	DPDT	5.5/2500.00	8 / 7	41	18	1.5 to 7	CONT	TOP	28 dc
6041H205	MS24185-D2	400	100	400	—	—	—	40	15	5	SPST	2.6/1181.82	1 / 5	60	18	1.5 to 7	CONT	SIDE	28 dc
6041H217	MS24185-D1	400	100	400	—	—	—	40	15	5	SPST	2.6/1181.82	1 / 1	60	18	1.5 to 7	CONT	TOP	28 dc

- ① Coil will exceed 95° C temperature rise when left on continuously in 25° ambient, but will not be damaged. At maximum ambient temperature of 71°C, the duty cycle should be limited to 15 minutes "on" time per half hour to obtain maximum coil life.
- ② Continuous and intermittent duty ratings shown are for N.O. pole rated at 1/2 the listed continuous DC duty ratings. N.C. pole on 6041H53 and H220 limited to 15 g's shock.
- ③ Time on 1 1/2 minutes at 29 Vdc. Minimum time off is 3 minutes.

- ④ All continuous duty resistive and motor load ratings and all intermittent duty ratings for all 3 pole relays listed under 28 Vdc apply for 120 Vdc systems with all 3 poles of the relay connected in the series.
- ⑤ Pick-up voltage below values shown may cause relay to rapidly cycle on and off (chatter).
- ⑥ Relay must drop-out at voltage value or less and may drop-out at any voltage below the higher voltage noted.

MS Part Number Summary			
AN3362-1*	6041H209		
MS24152-D1*	9565H29*	MS24185-D2	6041H205
MS24166-D1	6041H200	MS24187-D1	6041H220
MS24166-D2	6041H201	MS24187-D2	6041H230
MS24171-D1	6041H215	MS24192-D1	9565H2
MS24171-D2	6041H202	MS24193-D1	9565H94
MS24172-D1	6041H216	MS25031-D1B	6046H53
MS24172-D2	6041H203	MS24185-D1	6041H217
MS24178-D1	6041H219	MS25032-1	6046H46

*Inactive for new design

Conversion Part Number		
AN Part Number	Use MS Part Number	Safran Electrical & Power Part Number
3343-1	—	9565H13
3350-1	MS24166-D2	6041H201
3362-1	—	6041H209
3370-1	MS24171-D2	6041H202
3371-1	MS24172-D2	6041H203
3380-1	MS24185-D2	6041H205
—	MS25030-D1B	6041H51

Approximate Dimensions and Weights

Catalog Number	Ampere Ratings	Figure Number	Dimensions in Inches						Coil	Dimensions in Millimeters	Dimensions in Millimeters								
			Wide A	High B	Deep C	Mounting		Hole F			Net Stud G Power	Weight Lbs.	Wide A	High B	Deep C	Mounting		Hole F	Weight Grams
						D	E									D	E		
6041H11	100	1	3.27	3.13	2.08	—	2.75	0.27	.250-28 UNF	.138-32 UNC	1.4	83.06	79.5	52.83	—	69.85	6.86	636.36	
6041H53	50/25	2	2.63	3.14	2.062	—	2.2	0.214	.190-32 UNF-2A	.138-32 UNC-2A	0.54	66.8	79.076	52.37	—	55.88	5.44	245.45	
6041H80	100	3	2.91	3	2.08	—	2.26	0.276	.250-32 UNC	.138-32 UNC-2A	1.4	73.91	76.2	52.83	—	57.4	7.01	636.36	
6041H105	200	5	4.406	3.28	1.99	—	2.395	0.276	.375-24 UNF-2A	.138-32 UNC-2A	1.25	111.92	83.31	50.55	—	60.83	7.01	568.18	
6041H123	200	6	4.5	3.575	2	—	2.395	0.276	.375-24 UNF-2A	.138-32 UNC-2A	1.3	112.01	90.81	50.8	—	62.83	7.01	590.91	
6041H144	100	3	3.33	3	2	—	2.26	0.276	.250-28 UNF	.138-32 UNC	1.4	84.58	76.2	50.8	—	57.4	7.01	636.36	
6041H149	50	4	2.75	2.5	2.125	—	1.875	0.229	.190-32 UNC-2A	.138-32 UNC-2A	0.562	69.85	63.5	53.98	—	47.63	5.82	255.68	
6041H200	50	2	2.75	2.625	2.125	—	2.188	0.219	.191-32 UNC-2A	.138-32 UNC-2A	0.5	69.85	66.68	53.98	—	55.58	5.56	225	
6041H201	50	4	2.75	2.5	2.125	—	1.875	0.229	.190-32 UNC-2A	.138-32 UNC-2A	0.5	69.85	63.5	53.98	—	47.63	5.82	225	
6041H202	200	5	4.41	3.28	1.99	—	2.395	0.276	.375-24 UNF-2A	.138-32 UNC-2A	1.25	112.01	83.31	50.55	—	60.83	7.01	568.18	
6041H203	200	5	4.5	3.313	2	—	2.395	0.276	.375-24 UNF-2A	.138-32 UNC-2A	1.23	114.3	84.15	50.8	—	60.83	7.01	560	
6041H205	400	5	5.5	3.92	2.438	—	2.406	0.276	.500-20 UNF-2A	.138-32 UNC-2A	2.6	139.7	99.57	61.93	—	61.11	7.01	1181.82	
6041H209	100	2	3.469	3.406	2.656	—	2.948	0.276	.250-28 UNF-2B	.138-32 UNC-2B	1.5	88.11	86.51	67.46	—	74.88	7.01	681.82	
6041H210	200	5	4.48	3.313	2.466	—	3.717	0.27	.375-24 UNF-2A	.138-32 UNC-2A	1.3	113.79	84.15	62.64	—	94.41	6.86	590.91	
6041H215	200	1	4.406	3.75	2	—	3.01	0.276	.375-24 UNF-2A	.138-32 UNC-2A	1.33	111.91	95.25	50.8	—	76.45	7.01	604.55	
6041H216	200	1	4.406	3.75	2	—	3.01	0.276	.375-24 UNF-2A	.138-32 UNC-2A	1.33	111.91	95.25	50.8	—	76.45	7.01	604.55	
6041H217	400	1	5.5	4.5	2	—	3.01	0.276	.500-20 UNF-2A	.138-32 UNC-2A	2.6	139.7	114.3	50.8	—	76.45	7.01	1181.82	
6041H219	55	2	2.922	2.844	2.031	—	2.385	0.223	.190-32 UNC-2B	.138-32 UNC-2B	0.75	74.22	72.24	51.59	—	60.58	5.66	340.91	
6041H220	50/25	2	2.812	3.13	2.062	1.395	2.2	0.214	.190-32 UNF-2A	.137-32 UNC-2A	0.54	71.42	79.5	52.37	35.43	55.88	5.44	245.45	
6046H39	50/25	7	4.82	3.45	2.25	2.01	4.301	0.228	.190-32	.138-32 UNC	2.9	122.43	87.63	57.15	51.05	109.25	5.79	1318.18	
6046H46	200	7	7.688	4.125	3.468	1.76	6.895	0.266	.375-24 UNF	.138-32 UNC	5.5	195.28	104.78	88.09	44.7	175.13	6.76	2500	
6046H53	100	7	6.688	3.75	2.656	2.125	6.02	0.266	.250-28 UNF	.138-32 UNC	3.5	169.88	95.25	67.46	53.98	152.91	6.76	1590.91	
9565H2	25	11	3.063	2.75	2.75	2.688	2.49	0.229	.190-32 UNF-2B	.138-32 UNC-2B	1.062	77.8	69.85	68.28	63.25	5.82	482.95		
9565H13	100	11	3.812	3.546	3.28	2.468	3.102	0.225	.250-28 UNF-2B	.164-32 UNC-2B	2.5	96.82	90.07	83.31	62.69	78.79	5.72	1136.36	
9565H29	25	12	4.75	2.75	4.125	2.75	4.187	0.218	.190-32 UNF-2B	.164-32 UNC-2B	2.25	120.65	69.85	104.78	69.85	106.35	5.54	1022.73	
9565H94	50	11	3.625	3.188	3.312	2.135	2.322	0.219	.190-32 UNF-2B	.164-32 UNC-2B	1.5	92.08	80.98	84.12	64.23	58.98	5.56	681.82	
9565H95	25	11	3.063	2.75	2.75	—	2.494	0.229	.190-32 UNF-2B	.164-32 UNC-2B	1.06	77.8	69.85	69.85	—	63.35	5.82	481.82	

Note: All coils and auxiliary terminals are 6-32, except for Catalog Number 9565 relays which have 8-32 coil terminals. Dimensions are approximate and should not be used for construction purposes.

Dimension Figures

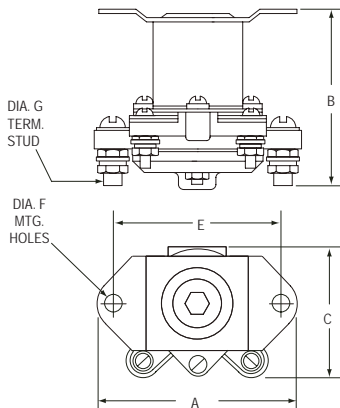

Figure 1

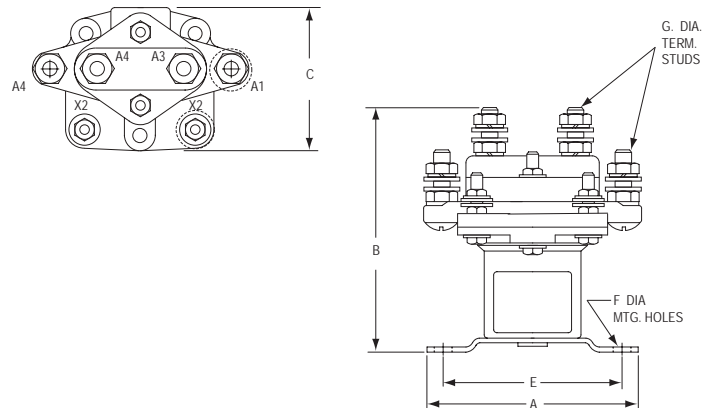

Figure 2

**POWER RELAYS — CONTINUOUS DUTY, TYPE II, UNSEALED
INTERMITTENT DUTY, TYPE III, UNSEALED**

Dimension Figures (cont.)

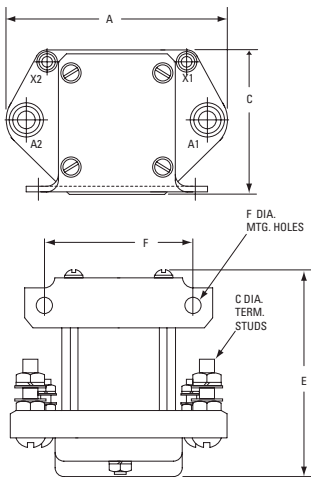

Figure 3

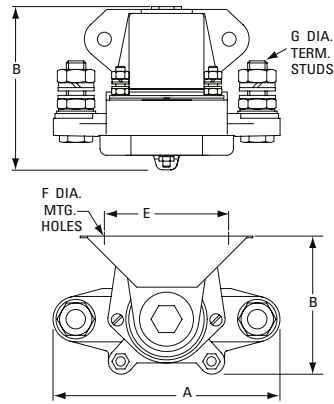

Figure 4

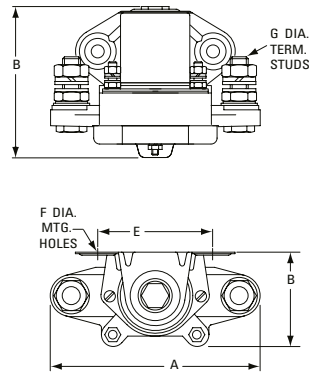

Figure 5

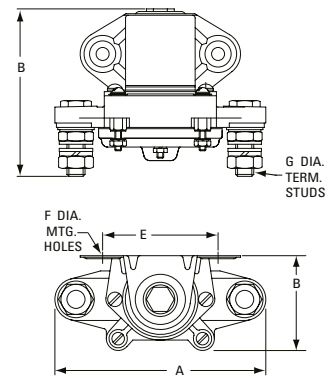

Figure 6

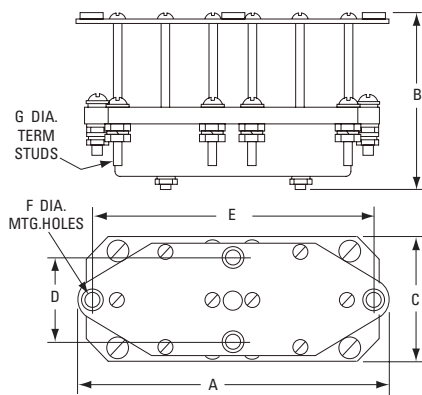

Figure 7

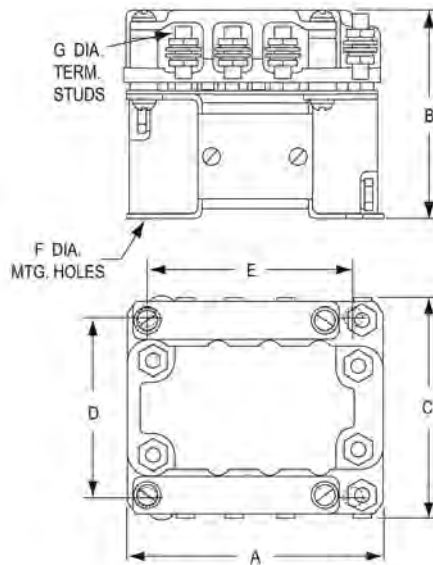

Figure 11

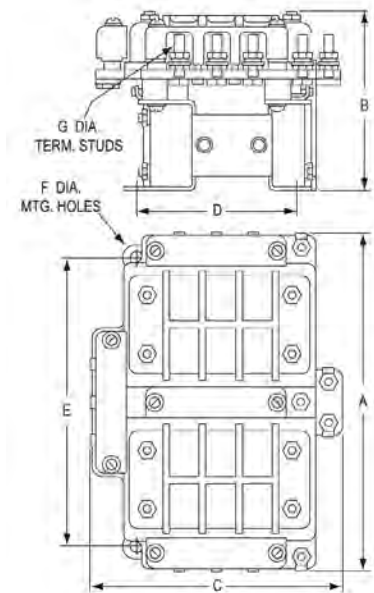

Figure 12

Typical Wiring Diagrams

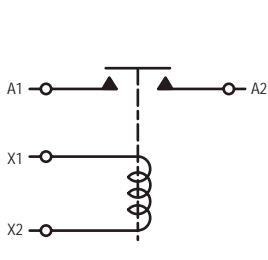

Diagram 1

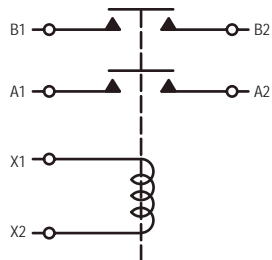

Diagram 2

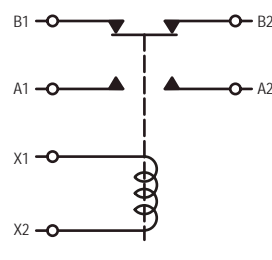

Diagram 3

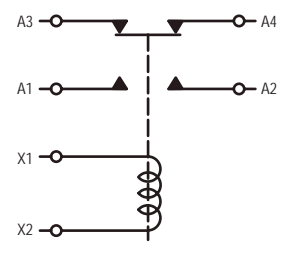

Diagram 4

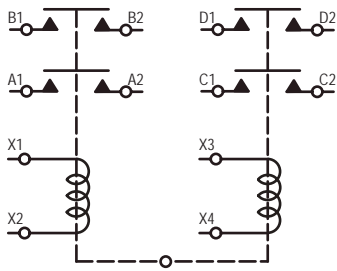

Diagram 8

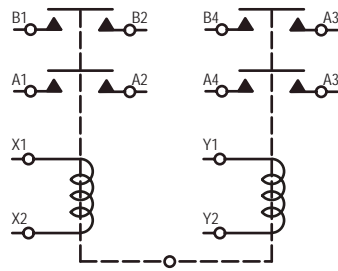

Diagram 9

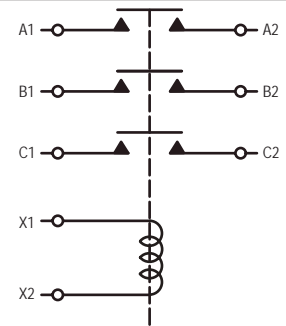

Diagram 10

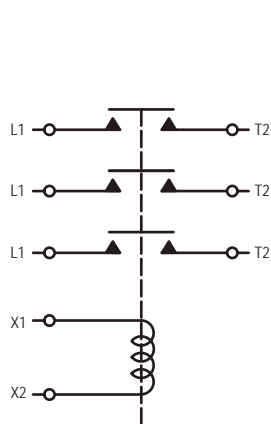

Diagram 12

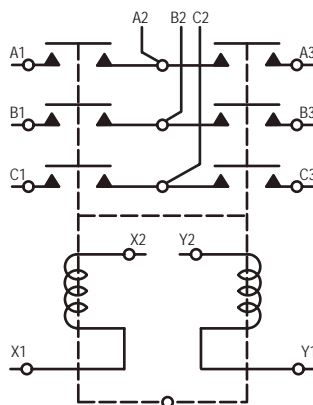

Diagram 16

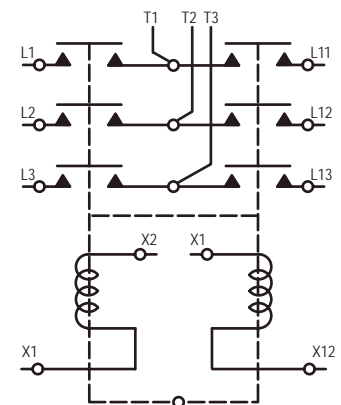

Diagram 18

POWER RELAYS — CONTINUOUS DUTY, TYPE II, UNSEALED INTERMITTENT DUTY, TYPE III, UNSEALED

P/N 6046H39

Typical Operation:

All items shown within dotted lines are part of the relay. All other parts external to dotted lines, including switches connected to C1 & C2 customer supplied.

Internal Mechanical Interlocks

Prevents the opposite contacts from transferring when either one of the coils is energized and the respective contacts are closed.

Reversing Operation

Closing either external start/stop switch at C1 or C2 will cause the motor to turn in either direction.

Dynamic Braking Operation

Internal switch provides for dynamic braking current flow through the motor shunt-fields series (SF) 1 and 2. Switch S is mechanically closed when either coil is energized and maintains that position until the alternate coil is energized. Switch S is shown in the last position commanded by external start/stop switch at C1.

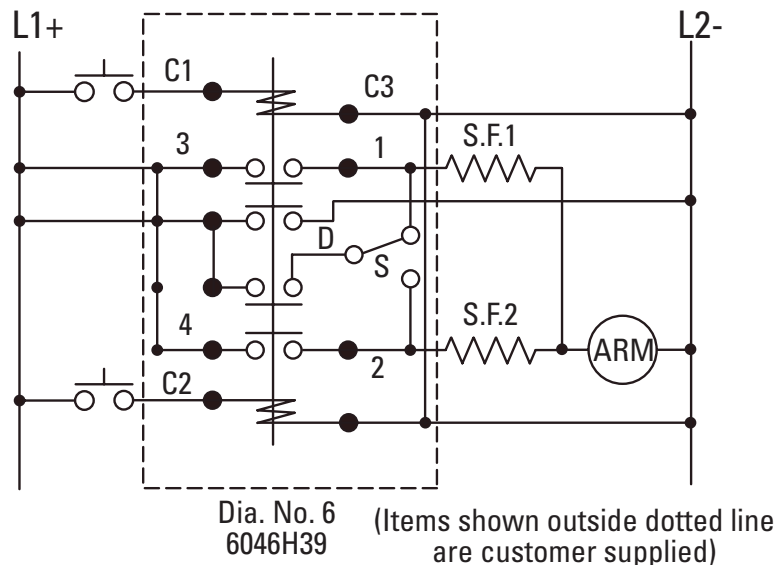

Characteristics:

- Electrical Life: 50,000 cycles (sea level to 80,000 feet)
- Mechanical Life: 100,000 cycles
- Acceleration: 15 g's
- Shock: 25 g's

- Ambient Temperature Class:
 - B -70°C to 125°C
 - D -70°C to 71°C
- Hermetically sealed/ MIL-PRF-6106
- Twin Break Silver Alloy Main Contacts

- Vibration Levels (Typical):

5 - 10 CPS .08 DA	10 - 55 CPS .06 DA	55 - 200CPS 10 g's
250 - 500 CPS 5 g's	500 - 1500 CPS 3 g's	

Typical Configurations

Catalog Number	Continuous Ampere Contact Rating	Poles and Throw	Operating Coil Voltage	Number Aux ^① Contacts	Dimension Drawing Figure Number	Wiring Diagram Figure Number	Government Type Number	Temp Class/ Note
6042H110-2	12	3PST	28 Vdc	1	2	8	MS24143-D3	B ^②
6042H141-2	25	3PST		—	2	6	MS24143-D1	B
6042H142-2				1	2	8	MS24143-D2	B ^②
6042H290-2			115 Vac 60 or 400 Hertz	—	2	6	MS24143-A3	D
6042H291-2			Built In Rectifiers	1	2	8	MS24143-A4	D
6042H155-2	50	SPST	28 Vdc	—	1	9	MS24140-D1	B
6042H156-2				1	1	10	MS24140-D2	B
6042H145-2				—	2	6	MS24376-D1	B
6042H146-2		1	2	8	MS24376-D2	B		
6042H147-2		3PST	115 Vac 60 or 400 Hertz	—	2	6	MS24376-A1	B ^③
6042H148-2				1	2	8	MS24376-A2	B ^③
6042H285-2				1	2	8	MS24376-A4	B ^③
6042H288-2				—	2	6	MS24376-A3	B ^③
				Built In Rectifiers				



Cat. No. 6042H285
3PST, 50 Amp w/Auxiliary



Cat. No. 6042H155
SPST, 50 Amp



Cat. No. 6042H46
SPST, 50 Amp w/Auxiliary

POWER RELAYS — HERMETICALLY SEALED - 12 AMPS TO 50 AMPS

Ratings

Power Contact Ratings - Continuous Duty ^①						Coil Data					Catalog Number	
28 Vdc			115/200 Vac 400 Hz			Max. Coil Power		Max. Volts Pick Up at Amb. Temp.	Volts			
Amperes			Amperes			Amps	Volts		Hold	Drop Out		
Res.	Ind.	Motor	Res.	Ind.	Motor							
12	12	6	12	12	6	0.6	29 dc	18 dc	7 dc	1.5 dc	6042H110-2	
25	25	25	25	25	25						0.6	0.225
			50 ^③	50 ^③	50 ^③	0.6	6042H142-2					
			50 ^④	50 ^④	50 ^④	0.50	6042H290-2					
50	50	50	50	50	50	0.50	29 dc	18 dc	7 dc	1.5 dc	6042H291-2	
			50	50	50	0.6					6042H155-2	
			50	50	50	0.6					6042H156-2	
50	50	50	50	50	50	0.225	124 ac	90 ac	40 ac	10 ac	6042H145-2	
			50	50	50						0.225	6042H146-2
50	50	50	50	50	50	0.225	124 ac	90 ac	40 ac	10 ac	6042H147-2	
			50	50	50						0.225	6042H148-2
			50	50	50						0.225	6042H285-2
											6042H288-2	

- ① Auxiliary Switch: SPDT rated 28 Vdc and 115 V 400 Hz, 5 Amp Res. & Ind. & 0.75 Amp Lamp
- ② Rated 100,000 operations electrical and mechanical life; Auxiliary switch rated 1,25 Amp Res. & 0.75 Amp Ind.
- ③ These Ratings for 115 V 400 Hz only
- ④ See MS Sheets for details
- ⑤ Intermittent duty ratings for general applications. (See chart below)
- ⑥ Ratings for 50/60 Hz only @ 115/200 Vac
- ⑦ 400 Hz only
- ⑧ Temperature Class D for 60 Hz AC Operation

Intermittent Duty Ratings

Continuous	15 Minutes	5 Minutes	1 Minute	Max. Inrush
100%	130%	150%	200%	600%

In general, these power relays can withstand the above intermittent duty overcurrent.

Options:

Internal Coil Suppression

Typical Configurations

Catalog Number	Continuous Ampere Contact Rating	Poles and Throw	Operating Coil Voltage	Number Aux. ^① Contacts	Dimension Drawing Figure Number	Wiring Diagram Figure Number	Government Type Number	Temp Class/ Note	Power Contact Ratings — Continuous Duty ^②						Max. Time In Seconds		Coil Data			Volts	
									28 Vdc Amperes			115/200 Vac 400 Hz Amperes			Operate	Release	Amps	Volts	Max. Volts Pick-up @ Amb Temp.	Hold	Drop Out
									Res.	Ind.	Motor	Res.	Ind.	Motor							
6042H159-2	100	SPST	28 Vdc	—	1	9	MS24141-D1	B	100	100	100	100 ^③	—	75 ^④	0.025	0.01	0.5	29 dc	18 dc	7 dc	1.5 dc
6042H160-2				1	1	10	MS24141-D2	B	100	100	100	100 ^③	—	75 ^④	0.025	0.01	0.5	29 dc	18 dc	7 dc	1.5 dc
6042H166-2				—	1	9	MS24182-D1	D	100	100	100	100 ^③	—	75 ^④	0.02	0.01	0.5	29 dc	18 dc	7 dc	1.5 dc
6042H161-2		3PST	115 Vac	—	2	6	MS24168-D1	B	100	100	100	100 ^③	50 ^⑤	100 ^⑤	0.06	0.015	0.6	29 dc	18 dc	7 dc	1.5 dc
6042H162-2				1	2	8	MS24168-D2	B	100	100	100	100	50 ^⑤	100	0.06	0.025	0.6	29 dc	18 dc	7 dc	1.5 dc
6042H286-2				—	2	8	MS24168-A4	D	100	100	100	100	50 ^⑤	100	0.06	0.11	0.25	120 ac	90 ac	40 ac	10 ac
6042H289-2	1	2	6	MS24168-A3	D	100	100	100	100	50 ^⑤	100	0.06	0.08	0.25	120 ac	90 ac	40 ac	10 ac			
6042H151-2	200	SPST	28 Vdc	—	1	9	MS24142-D1	B	200	100	200	200	—	150	0.035	0.015	0.6	29 dc	18 dc	7 dc	1.5 dc
6042H152-2				—	1	10	MS24142-D2	B	200	100	200	200	—	150	0.035	0.015	0.6	29 dc	18 dc	7 dc	1.5 dc
6042H167-2				1	1	9	MS24183-D1	D	200	100	200	200	—	150	0.03	0.01	0.5	29 dc	18 dc	7 dc	1.5 dc
6042H153-2	300			—	1	9	MS24184-D1	D	300	100	250	300	—	150	0.035	0.015	0.6	29 dc	18 dc	7 dc	1.5 dc
6042H154-2				1	1	10	—	D	300	100	250	300	—	150	0.035	0.015	0.6	29 dc	18 dc	7 dc	1.5 dc
SM400H2-2	400			—	1	9	—	D	400	100	250	400	—	150	0.035	0.015	0.6	29 dc	18 dc	7 dc	1.5 dc
SM400H3-2				1	1	10	—	D	400	100	250	400	—	150	0.035	0.015	0.6	29 dc	18 dc	7 dc	1.5 dc

①Auxiliary switch: SPDT rated 28 Vdc and 115 V 400 Hz, 5 Amp Res. & Ind. & 0.75 Amp Lamp.
 ②Rated 100,000 operations electrical and mechanical life. Auxiliary switch rated 1.25 Amp Res. & 0.75 Amp Ind.
 ③Rated 50 g shock.
 ④These ratings for 115 V 400 Hz only.
 ⑤See MS Sheets for details.
 ⑥Intermittent duty ratings for general applications (see chart below).
 ⑦Ratings for 50/60 Hz only @ 115/200 Vac.



Cat. No. 6042H286
3 PST, 100 Amp



Cat. No. 6042H151
SPST, 200 Amp



Cat. No. 6042H153
SPST, 300 Amp

Characteristics:

- Electrical Life: 50,000 cycles (sea level to 80,000 feet)
- Mechanical Life: 100,000 cycles
- Acceleration: 15 g's
- Shock: 25 g's
- Ambient Temperature Class:
 - B -70°C to 125°C
 - D -70°C to 71°C
- Hermetically sealed/ MIL-PRF-6106

- Twin Break Silver Alloy Main Contacts
- Vibration Levels (Typical):

5-10 CPS .08 DA	10-5 CPS .06 DA	55-200CPS 10 g's
250-500 CPS 5 g's	500-1500 CPS 3 g's	

Intermittent Duty Ratings:

Continuous	15 Minutes	5 Minutes	1 Minute	Max. Inrush
100%	130%	150%	200%	600%

In general, these power relays can withstand the above intermittent duty overcurrent.

Options:

Internal Coil Suppression

Approximate Dimensions and Weights

Catalog Number	Ampere Rating	Dimensions in Inches	Dimensions in Inches						Net Term. Stud Dia. G		Weight	Dimensions in Millimeters						Weight
			Wide	High	Deep	Mounting		Hole	Lbs.	Wide		High	Deep	Mounting		Hole	Grams	
			A	B	C	D	E	F		Power	Coil	A	B	C	D	E		F
6042H110-2	12	2	3.305	4.485	3.700	3.250	2.687	0.218	.190-32 UNF-2B	.138-32 UNC-2B	1.60	83.95	113.92	93.98	82.55	68.25	5.54	727.27
6042H141-2	25	2	3.305	3.250	3.700	3.250	2.687	0.218	.190-32 UNF-2B	.138-32 UNC-2B	1.50	83.95	82.55	93.98	82.55	68.25	5.54	681.82
6042H142-2	25	2	3.305	4.513	3.700	3.250	2.687	0.218	.190-32 UNF-2B	.138-32 UNC-2B	1.60	83.95	114.63	93.98	82.55	68.25	5.54	727.27
6042H145-2	50	2	3.305	3.200	3.700	3.250	2.687	0.218	.190-32 UNF-2B	.138-32 UNC-2B	1.60	83.95	81.28	93.98	82.55	68.25	5.54	727.27
6042H146-2	50	2	3.305	4.485	3.700	3.250	2.687	0.218	.190-32 UNF-2B	.138-32 UNC-2B	1.70	83.95	113.92	93.98	82.55	68.25	5.54	771.11
6042H147-2	50	2	3.305	3.200	3.700	3.250	2.687	0.218	.190-32 UNF-2B	.138-32 UNC-2B	1.70	83.95	81.28	93.98	82.55	68.25	5.54	771.11
6042H148-2	50	2	3.305	4.485	3.700	3.250	2.687	0.218	.190-32 UNF-2B	.138-32 UNC-2B	1.82	83.95	113.92	93.98	82.55	68.25	5.54	825.54
6042H151-2	200	1	3.640	3.700	3.315	—	3.000	0.266	.375-24 UNF-2B	.138-32 UNC-2B	2.30	92.46	93.98	84.20	—	76.20	6.76	1043.26
6042H152-2	200	1	3.640	4.972	3.315	—	3.000	0.266	.375-24 UNF-2B	.138-32 UNC-2B	2.50	92.46	126.29	84.20	—	76.20	6.76	1133.98
6042H153-2	300	1	3.640	3.700	3.315	—	3.000	0.266	.375-24 UNF-2B	.138-32 UNC-2B	2.40	92.46	93.98	84.20	—	76.20	6.76	1088.62
6042H154-2	300	1	3.640	4.973	3.315	—	3.000	0.266	.375-24 UNF-2B	.138-32 UNC-2B	2.50	92.46	126.31	84.20	—	76.20	6.76	1133.98
6042H155-2	50	1	2.700	2.665	2.835	—	2.188	0.218	.190-32 UNF-2B	.138-32 UNC-2B	0.90	68.58	67.69	72.01	—	55.58	5.54	408.23
6042H156-2	50	1	2.700	3.947	2.835	—	2.188	0.218	.190-32 UNF-2B	.138-32 UNC-2B	1.10	68.58	100.25	72.01	—	55.58	5.54	498.95
6042H159-2	100	1	3.640	3.250	2.925	—	3.000	0.266	.250-28 UNF-2B	.138-32 UNC-2B	1.40	92.46	82.55	74.30	—	76.20	6.76	635.03
6042H160-2	100	1	3.640	4.532	2.925	—	3.000	0.266	.250-28 UNF-2B	.138-32 UNC-2B	1.60	92.46	115.11	74.30	—	76.20	6.76	727.27
6042H161-2	100	2	4.250	4.280	4.220	3.697	3.510	0.218	.250-28 UNF-2B	.138-32 UNC-2B	3.30	107.95	107.57	107.19	93.90	89.15	5.54	1496.86
6042H162-2	100	2	4.250	5.615	4.220	3.697	3.510	0.218	.250-28 UNF-2B	.138-32 UNC-2B	3.45	107.95	142.62	107.19	93.90	89.15	5.54	1568.18
6042H166-2	100	1	3.640	3.063	2.925	—	3.000	0.266	.250-28 UNF-2B	.138-32 UNC-2B	1.10	92.46	77.80	74.30	—	76.20	6.76	498.95
6042H167-2	200	1	3.672	3.282	2.957	—	3.000	0.266	.375-24 UNF-2B	.138-32 UNC-2B	1.70	93.27	83.36	75.11	—	76.20	6.76	771.11
6042H285-2	50	2	3.305	4.485	3.700	3.250	2.687	0.218	.190-32 UNF-2B	.138-32 UNC-2B	1.90	83.95	113.92	93.98	82.55	68.25	5.54	861.83
6042H286-2	100	2	4.235	5.553	4.218	3.697	3.510	0.218	.250-28 UNF-2B	.138-32 UNC-2B	3.70	107.57	141.05	107.14	93.90	89.15	5.54	1678.29
6042H288-2	50	2	3.305	3.200	3.700	3.250	2.687	0.218	.190-32 UNF-2B	.138-32 UNC-2B	1.80	83.95	81.28	93.98	82.55	68.25	5.54	816.47
6042H289-2	100	2	4.235	4.280	4.218	3.697	3.510	0.218	.250-28 UNF-2B	.138-32 UNC-2B	3.60	107.57	108.71	107.14	93.90	89.15	5.54	1636.36
6042H290-2	25	2	3.305	3.250	3.700	3.250	2.687	0.218	.190-32 UNF-2B	.138-32 UNC-2B	1.70	83.95	82.55	93.98	82.55	68.25	5.54	771.11
6042H291-2	25	2	3.305	4.513	3.700	3.250	2.687	0.218	.190-32 UNF-2B	.138-32 UNC-2B	1.90	83.95	114.63	93.98	82.55	68.25	5.54	861.83
SM400H2-2	400	1	3.640	3.700	3.315	—	3.000	0.266	.375-24 UNF-2B	.138-32 UNC-2B	2.40	92.46	93.98	84.20	—	76.20	6.76	1088.62
SM400H3-2	400	1	3.640	4.973	3.315	—	3.000	0.266	.375-24 UNF-2B	.138-32 UNC-2B	2.50	92.46	126.31	84.20	—	76.20	6.76	1133.98

NOTE: All coils and auxiliary terminals are 6-32. Dimensions are approximate and should not be used for construction purposes.

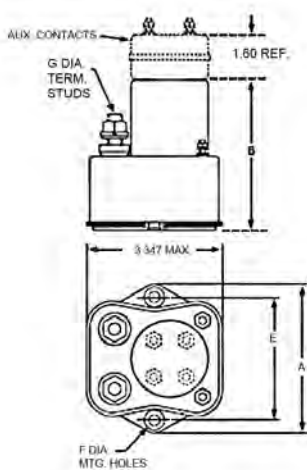

Figure 1

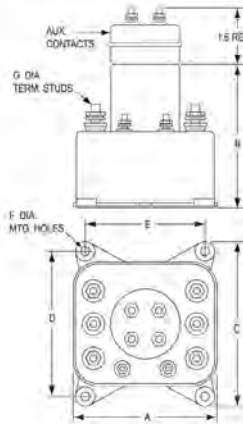
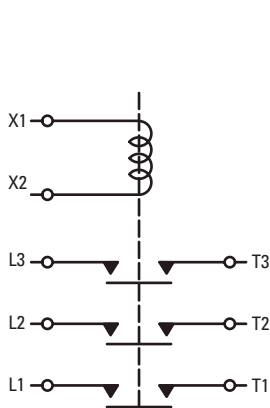
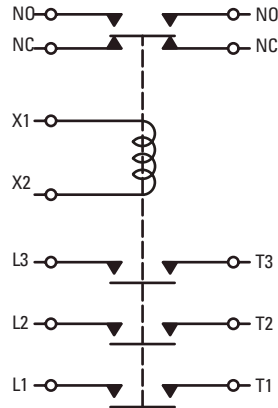

Figure 2

Typical Wiring Diagrams (See Selection Table for Diagram No. Reference)



Dia. No. 1



Dia. No. 2

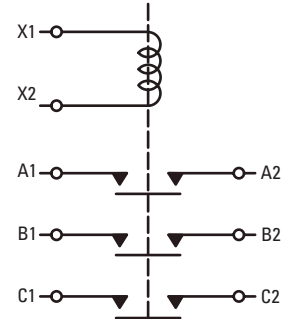

Dia. No. 6

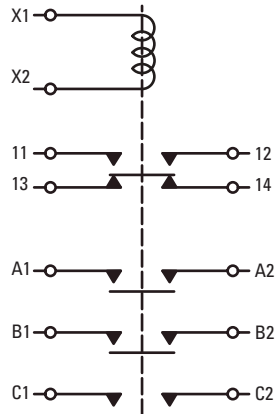

Dia. No. 7

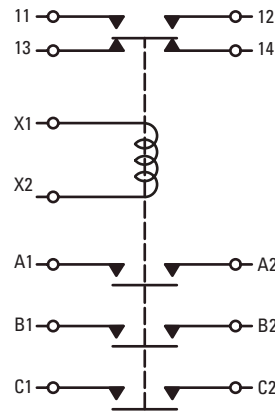

Dia. No. 8

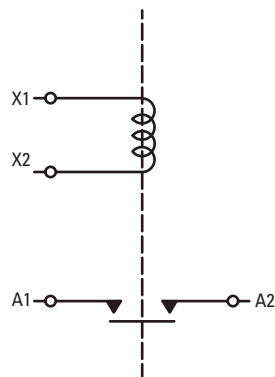

Dia. No. 9

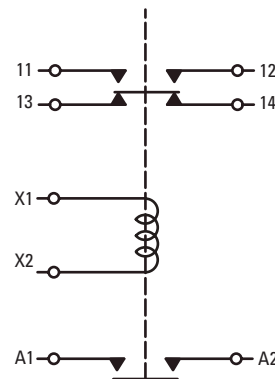

Dia. No. 10

Specifications

- Molded of unbreakable nylon
- Ambient temperature ranges: -70°C to 125°C
- Secured by coil terminal hardware
- Part number molded into cover
- Positive protection between power stubs



Part No. 49-2665
MS27242-1



Part No. 49-2667
MS27243-3



Part No. 49-2661
MS27243-1



Part No. 49-2670
MS27243-4

Terminal Covers Application

Safran Electrical & Power Relays	Relay MS Numbers	Terminal Cover Part Number	MS27243
6042H110-2	MS24143-D3	49-2661	-1
26042H141-2	MS24143-D1	49-2661	-1
6042H142-2	MS24143-D2	49-2661	-1
6042H145-2	MS24376-D1	49-2661	-1
6042H146-2	MS24376-D2	49-2661	-1
6042H147-2	MS24376-A1	49-2661	-1
6042H148-2	MS24376-A2	49-2661	-1
6042H151-2	MS24142-D1	49-2672	-5
6042H152-2	MS24142-D2	49-2672	-5
6042H153-2	MS24184-D1	49-2672	-5
6042H154-2	MS24184-D2	49-2672	-5
6042H155-2	MS24140-D1	49-2667	-3
6042H156-2	MS24140-D2	49-2667	-3
6042H159-2	MS24141-D1	49-2665	-2
6042H160-2	MS24141-D2	49-2665	-2
6042H161-2	MS24168-D1	49-2670	-4
6042H162-2	MS24168-D2	49-2670	-4
6042H166-2	MS24182-D1	49-2667	-3
6042H167-2	MS24183-D1	49-2665	-2
6042H286-2	MS24168-A4	49-2670	-4
6042H288-2	MS24376-A3	49-2661	-1
6042H289-2	MS24168-A3	49-2670	-4
6042H290-2	MS24143-A3	49-2661	-1
6042H291-2	MS24143-A4	49-2661	-1
SM400H2-2	—	49-2672	-5
SM400H3-2	—	49-2672	-5

Approximate Dimensions and Weights

Part Number	Figure Number	Dimensions in In./Mill.			Ship Wt. Lbs./ gm
		A	B	C	
49-2661	1	2.32/58.93	0.75/19.05	2.94/74.68	.025/11.31
49-2665	1	2.56/65.02	1.17/29.72	2.12/53.85	.026/11.77
49-2667	1	2.66/67.56	1.11/28.19	2.05/52.07	.027/12.22
49-2670	1	2.75/69.85	1.06/26.92	3.81/96.77	.044/19.91
49-2672	1	3.00/76.20	1.17/29.72	2.50/63.50	.030/13.57

NOTE: Dimensions are approximate and should not be used for construction purposes.

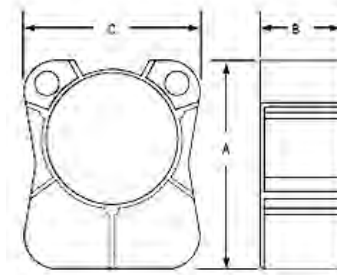

Figure 1

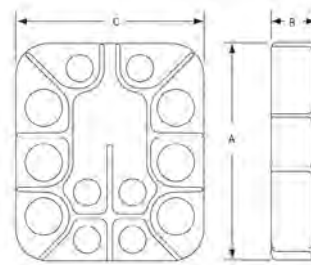

Figure 2

Engineering Data

- MIL-R-6106 Type I
 - Hermetically Sealed
 - Continuous Duty
- Weight - 11.3 oz. (320 grams)
- Seal - 1x10⁻⁶ STD CC/SEC Max
- Altitude: 80,000 Feet
- Double Break Contacts

Vibration Random		15 Minutes Each Plane	Vibration Random		15 Minutes Each Plane
M6106/48-001			M6106/48-002 ^①		
Frequency (Hz)		Level (g ² /Hz)	Frequency (Hz)		Level (g ² /Hz)
10 - 125		0.037	15 - 50		0.012
125 - 250		+4 dB	120 - 200		0.364
250 - 1000		0.1	250 - 400		0.194
1000 - 2000		-3 dB	600 - 1000		0.060
			1300 - 2000		0.097

^①Test to be performed with 5 ampere load on main contact.

Selection Table



- SM100H1
- M6106/48-001

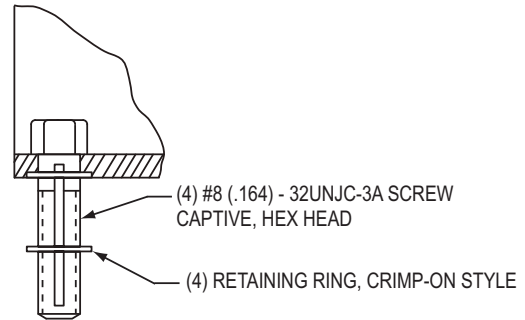

- SM100H15
- M6106/48-002

Application Notes

The curve shows a typical motor/generator requirement. The SM100H1 can withstand up to 400 Amps for several seconds during motor start - dropping to 100 Amps within 5 seconds. The SM100H1 can withstand the generator output up to 200 Amp for several minutes - dropping to 100 Amps within 3.5 minutes. These cycles can be repeated once every 90 seconds. The SM100H1 will meet applications requiring a reliable and robust contactor.

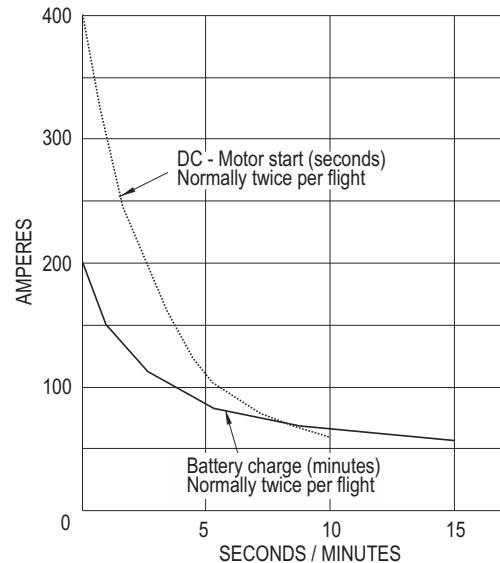

Engineering Data

- Meets MIL-R-6106/48
Type I Hermetically Sealed Continuous Duty
- Power Contacts SPST:
 - 28 Vdc
 - Load Ratings:
 - Resistive: 100 Amps
 - Inductive: 100 Amps (10,000 cycles)
 - Motor: 50 Amps -001; 25 amps -002
 - Lamp: 50 Amps (25,000 cycles)
 - Minimum: 10 Amps
 - Overload: 800 Amps (See application curve)
 - Rupture: 1000 Amps
 - Contact Voltage Drop:
 - Initial 0.100 V
 - After Test - 0.150 V
- Life:
 - Electrical: 50,000 cycles
 - Mechanical: 100,000 cycles
- Auxiliary Contacts SPDT Form "Z":
 - Voltage: 28 Vdc
 - Resistive: 5 Amps
 - Inductive: 5 Amps (10,000 cycles)
 - Lamp: 1 Amp (25,000 cycles)
 - Minimum: 2 MA at 28 Vdc.
 - Contact Voltage Drop: Maximum: 5 MV +/- 100 MA and 6V
- Current above 125 MA negates minimum current capability.
- Operating Temperature: -55°C to 125°C
- Shock: ½ Sine 50 g's 6-9 MS:
 - Contact Opening: 2 millsec. max.
- Insulation Resistance Minimum:
 - Initial: 100 Megohms
 - After Test: 50 Megohms
- Vibration: Sinusoidal (-001 only)
 - 5 to 10 Hz 0.08 DA
 - 10 to 55 Hz 0.05 DA
 - 55 to 2000 Hz 10 g's
- Vibration (Gun Fire) 15 minutes each plane:
 - 0.0375 g/Hz for 10 to 125 Hz
 - 4DB/Octave inc 125 to 250 Hz
 - 0.1 g/Hz for 250 to 1000 Hz
 - 3DB/Octave decrease 1000 to 2000 Hz
- Dielectric Strength Sea Level 2-5 sec. Voltage=VRMS 60 Hz:
 - All points: 1250 V Initial, 1000 V After Tests
- Dielectric Strength Altitude 1 min. 60 Hz:
 - Coil & contacts: 500 V Initial & After Test
 - All other points: 500 V Initial & After Test

Dimensions

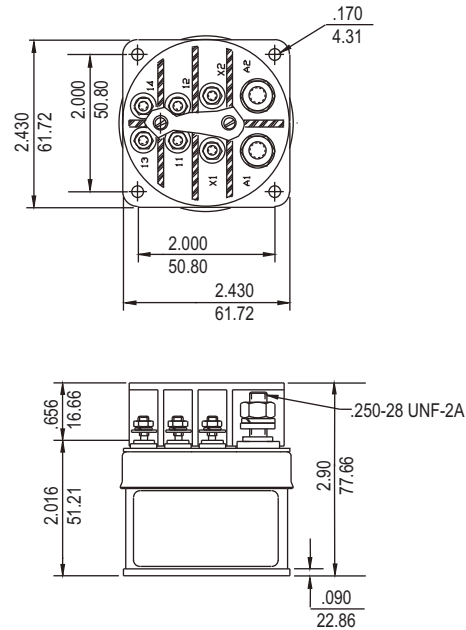

Schematic

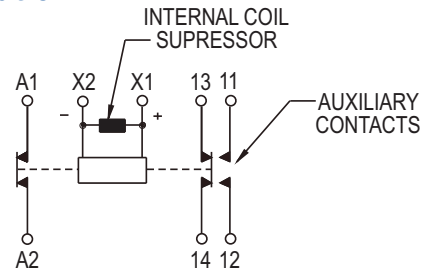

Coil Data

- Duty Cycle: Continuous
- Maximum Voltage: 30 Vdc
- Pick up: 18 Vdc (15 Vdc at 25°C)
- Hold-in: Unit must drop out at 1.5 Vdc & below and can drop out at any voltage below 7 Vdc.
- Operate Time: 30 MS maximum
Release Time: 20 MS maximum
- Contact Bounce: 3 MS maximum main and auxiliary contacts
- Coil Resistance:
 - @-25°C; 100 Ohms minimum (-002); 90 Ohms Minimum (-001)
- Coil Suppression: 0.42 V max. Peak Inverse Voltage

Engineering Data

- Meets MIL-R-6106 Type IV
- Weight: 10.5 ounces (284 g)
- Altitude:
 - Rated: 50,000 feet
 - Extended: 80,000 feet with encapsulated terminals
- Ratings:
 - Voltage: 115/200V, 400 Hz, 3Æ
 - Load Ratings:
 - Resistive: 60 Amps
 - Inductive: 60 Amps
 - Motor: 40 Amps
 - Minimum Current: 4 Amps
 - Rupture: 400 Amps
- Environmental Seal: MIL-STD-202, METHOD 112 Test Condition C Procedure IV
- Seal: 6 x 10-4 STD CC/SEC
- Economizer Coil: 30 Vdc
 - Inrush: 1.25 Amps (20 milliseconds max)
 - Steady State: 0.25 Amps

Power Contact Ratings (Continuous Duty)^①

	115/200 Vac 400 Hz	28 Vdc
• Resistive	60 A.	20 A.
• Inductive	60 A.	10 A.
• Motor	40 A.
• Minimum Current	4 A.
• Rupture	400 A.
• Contact Drop		
- Initial	0.150 V Max.
- After Life Test	0.175 V. Max.
• Contact Bounce	2 Milliseconds	

^① DC ratings are maximum overload capability. By wiring two poles in series, 28 Vdc rating can be increased to the same as the full AC ratings.

Options

- AC operated coils
- Encapsulated terminals
- Internal coil suppression
- Suitable for synchronized power supplied transfer

Selection Table

Poles and Throw-Circuit	Number of Auxiliary Contacts 1 P.D.T.	Government Type Number M6106	Catalog Number
3 P.S.T.-N.O.	—	/10-001	SM15AWD1
	1	/10-002	SM15AXD1
3 P.S.T.-N.C.	—	/11-001	SM15BWD1
	1	/11-002	SM15BXD1
3 P.D.T.	—	/9-001	SM15CWD1
	1	/9-002	SM15CXD1
3 P.S.T.-N.O.	—	10-005*	SM15AWD3

* Unit supplied with internal coil suppression. 45 V max. peak inverse voltage.



Typical Wiring Diagrams

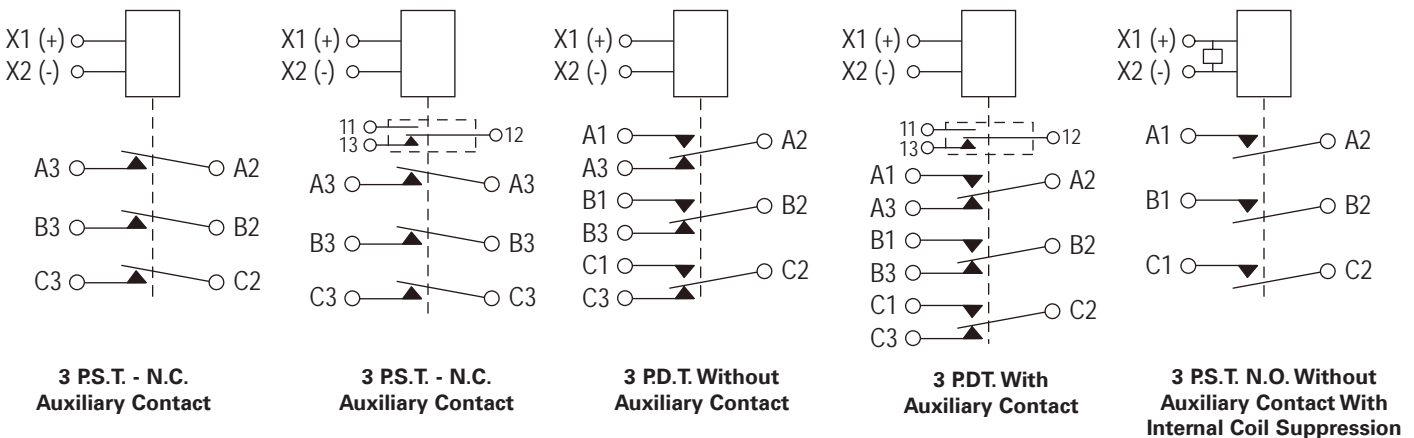

Engineering Data

Specifications

- Meets MIL-R-6106/9, /10, /11 Type IV Environmentally Sealed
 - Continuous Duty Operation
- Power Contacts 400 Hz:
 - Voltage: 115 V Single Phase
115 V/ 200 V Three Phase
 - Load Ratings per Pole:
 - Resistive: 60 Amps
 - Inductive: 60 Amps
 - Motor: 40 Amps
 - Minimum Current: 4 Amps
 - Overload: 320 Amps
 - Rupture: 400 Amps
 - Electrical Life at Rated Loads: 100,000 operations (50,000 motor)
 - Mechanical Life at 15 Amps: 200,000 operations
- Auxiliary Contacts 115 V 400 Hz/ 28 Vdc:
 - Resistive: 3 Amps
 - Inductive: 1.5 Amps
 - Mechanical: 0.5 Amps
- Operating Temperature: -55°C to 71°C
- Shock: ½ Sine, 25 g's 6 to 9 MS
 - Contact Opening: 1 millisecond maximum
- Acceleration: 15 g's
- Insulation Resistance Minimum
 - Initial: 200 Megohms
 - After Test: 100 Megohms
- Vibration:
 - 5 to 10 Hz 0.08" DA
 - 10 to 55 Hz 0.06" DA
 - 55 to 400 Hz 10 g's
 - 400 to 800 Hz 8 g's
 - 800 to 2000 Hz 8 g's (-55°C to 25°C) 7 g's at 71°
- Dielectric Strength Sea Level 2-5 sec. 60 Hz:
 - Coil & Auxiliary Contacts: 1250 V Initial, 1000 V After Test,
 - Across open power contacts: 1250 V Initial 625 V After Life.
 - All Other Points: 1800 V Initial, 1350 V After Test
- Dielectric Strength Altitude 1 minute 60 Hz:
 - Coil & Auxiliary Contacts: 500 V Initial & After Test
 - All Other Points: 700 V Initial & After Test

Coil Data

- 28 Vdc: Inrush 1.25 Amps (20 MS Max); Steady State 0.25 Amps
- Pick-up: 17 Vdc. Hold in: 7.0 Vdc
Drop-out: 1.5 Vdc Unit must drop out at 1.5 Vdc and below and can drop out at any voltage below 7 Vdc.
- Operate Time: 25 MS. Release Time: 25 MS
- Contact Bounce: 2 MS maximum main and auxiliary contacts

Dimensions Drawings

Top View - SM15CXD1 3PDT and Auxiliary Contacts

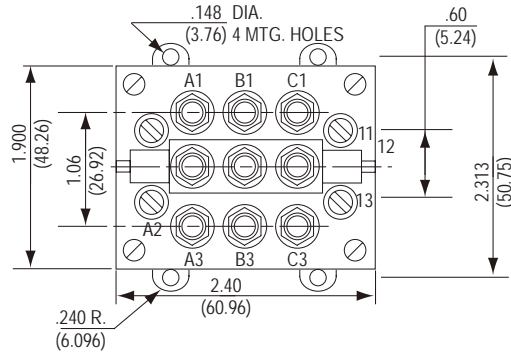

Top View - SM15AWD1 3 PST N.O. Contacts. Without Auxiliary Contacts

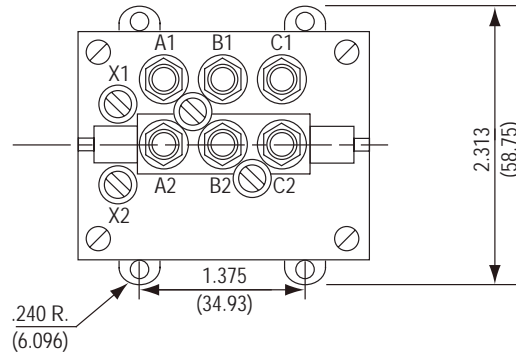

Side View

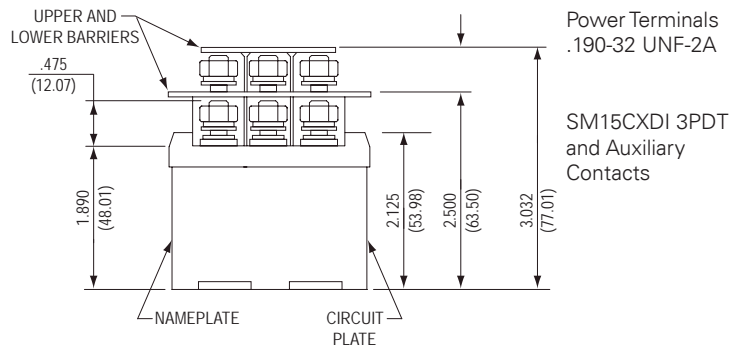

Engineering Data

Specifications

- Designed to MIL-R-6106/42
- All moving parts, contacts, and magnet coil gasket sealed & vented
- Operable at altitudes to 50,000 feet
- Operating Temperature: -55°C to +71°C
- Altitude: 50,000 ft. Max.
- Vibration:
 - Per MIL-E-5400
 - Curve IV, 5-2000 Hz
- Shock: 30 g's, Half Sine, 11 MS Duration
- Acceleration: 6 g's
- Maximum weight: 3.15 Lbs/1425.31 gm
- Overload Current: 1080 Amps
- Rupture Current: 1350 Amps

Electrical Characteristics

Insulation Resistance (Initial):..... 200 Megohms
 After Life or Environmental Tests:..... 100 Megohms

Contact Voltage Drop (Initial):..... MAIN 0.175 V max. - .150 V avg
 After Life Test 0.200 V max. - .175 V avg

Contact Voltage Drop (Initial)..... AUX 0.400 V max. - .300 V avg
 After Life Test 0.450 V max. - .400 V avg
 At 5 Amps

Overload Current (Main) 1080 amp

Rupture Current (Main) 1350 amp

Duty Rating Continuous

Coil Suppression to meet requirements of MIL-E-6051D(1)

Application Notes

Mechanically interlocked contact circuits prevent inadvertent operation of the alternate contact circuits. These units are suitable for load transfer typically from ground support to on-board power.

Dielectric Strength

Description	Test Voltage Vrms					
	At Sea Level (2-5 Sec.)				At Altitude (60 Sec.)	
	Initial		After Life		28 Vdc	115 Vac
28 Vdc	115 Vac	28 Vdc	115 Vac			
Coil to Case	1250	—	1000	—	500	—
Aux. Contacts	1250	1500	1000	1125	500	500
All Other Points	NA	1800	NA	1350	NA	700

Operating Characteristics

Coil Data							** Drop-Out Voltage	Time Milliseconds Max.				
Nominal	Max *	Amp		Pick-Up Volts				Coil Voltage			Bounce Time at 28 Vdc	
Volts	Volt	In Rush	Cont.	At 25°C	Hi Temp	Count Cur.		18 Vdc	23 Vdc	30 Vdc	Main	Aux.
28DC	30	5	1	15DC	18DC	22.5 DC		Operate	Release	Transfer		
							7+0/-6	50	35	10	2	4

* Pick-Up: Coil will operate at the voltages shown and higher.

** Drop-Out: Coil will drop out at 1 Vdc and may drop out at any voltage from 7 Vdc and below.

Rated Contact Load — (Amps per pole) Case Grounded

Type of Load	Life Operating Cycles X10 ³	28 Vdc				115 Vac 1 Phase 400 Hz				115/200 Vac 3 Phase 400 Hz			
		Main		Aux.		Main		Aux.		Main		Aux.	
		N.O.	N.C.	N.O.	N.C.	400 Hz	60 Hz	400 Hz	60 Hz	400 Hz	60 Hz	400 Hz	60 Hz
Resistive	50	120*	—	5	5	135	—	5	—	135	—	5	—
Inductive	50	—	—	3	3	135	—	3	—	135	—	3	—
Motor	50	—	—	—	—	80	—	—	—	80	—	—	—
Lamp	—	—	—	2	2	—	—	2	—	—	—	2	—
Transfer Load	10	—	—	—	—	135	—	—	—	135	—	—	—
Mech. Life Reduced Amps													
	100	—	—	1.25	1.25	33.75	—	1.25	—	33.75	—	1.25	—
Interm. Current	50	13.5	13.5	Per MIL-R-6106									

* Room Ambient conditions 100,000 operations.

Engineering Data

- Construction: Gasket Sealed (vented) - MIL - R - 6106 Type III, except as noted
- Ratings:
 - Main Contacts
 - Configuration: SPST N.O.
 - Voltage (Nominal): 28 Vdc
 - Current
 - Resistive: 400 Amp (Terminal Temperature Rise 85°C above 71°C Ambient)
 - Inductive: 100 Amps
 - Motorload: 400 Amps
 - Overload: 2,000 Amps
 - Custom Motor Current: See Graph 20,000 cycles (Min.)
 - Motor Current test to be run 5 cycles per hour maximum with 90 seconds off time between cycles
- Life:
 - Electrical: 50,000 Cycles Minimum
 - Mechanical: 100,000 Cycles
 - Weight: (Max.): 2.25 Lbs/ 1020.58 gm
- Environmental Data
 - Ambient Temp: -55°C to +71°C
 - Altitude: 50,000 Feet Maximum
 - Vibration:
 - 5 to 14 Hz 0.2" Double Amplitude
 - 14 to 33 Hz 2 g
 - 33 to 52 Hz 0.036" Double Amplitude
 - 52 to 500 Hz 5 g (peak)
 - 12 g Maximum (Steady State Load)
 - Acceleration:
 - Shock:
 - G-Level: 25 g's
 - Duration: 6 to 9 Milliseconds
 - Max. Duration Contact Opening
- Coil Data:
 - Duty Cycle: Continuous, Economizing
 - Nom. Operating Voltage: 28 Vdc
 - Pick-Up Voltage: 18 Vdc Max. at 25°C
 - Drop-Out Voltage: 0.75-3.50 Vdc at 25°C
 - Hold Voltage: 9 Vdc
 - Operating Time: 35 Milliseconds Maximum
 - Inrush Current: 3.0 Amps Max for 50 Milliseconds Max. at 25°C
 - Hold Current: 1.2 Amps Max. at 25°C
- Auxiliary Contacts:
 - Voltage: 28 Vdc or 115 V, 400 Hz
 - Current: 5 Amp Resistive

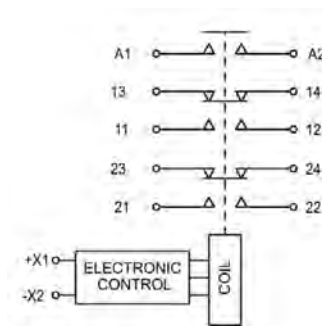
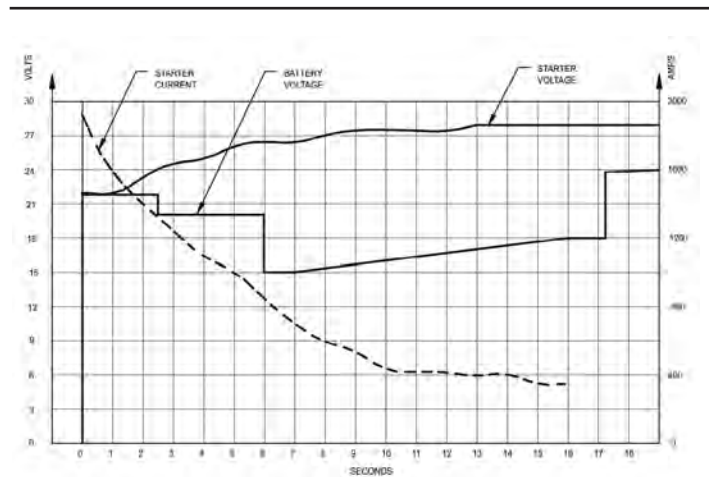

Electronic Control will add coil turns to compensate for low battery voltage during starter operation.

Options

- Low Level Auxiliary Contacts
- Auxiliary Terminal Size and Length

Typical Configurations — 400 Amp

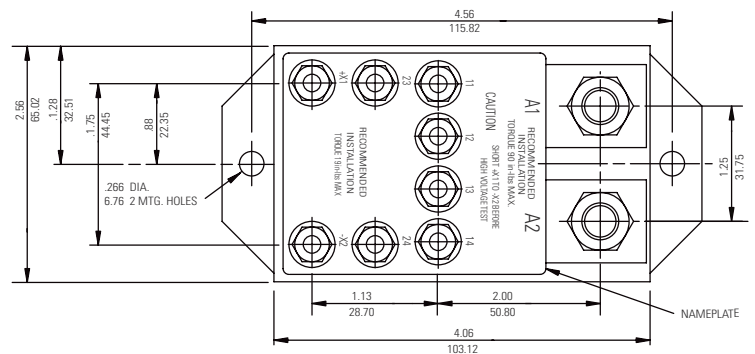
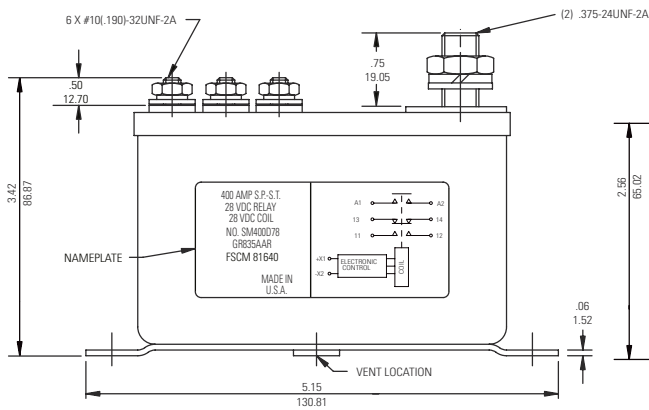
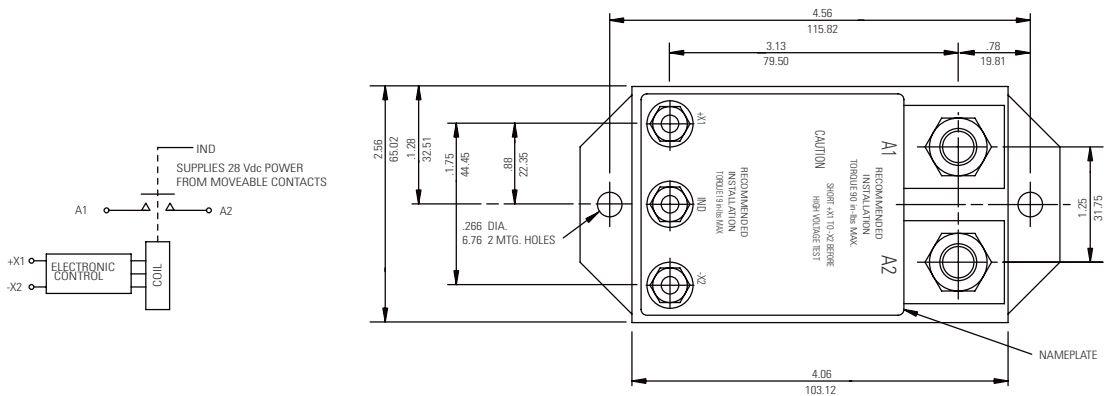
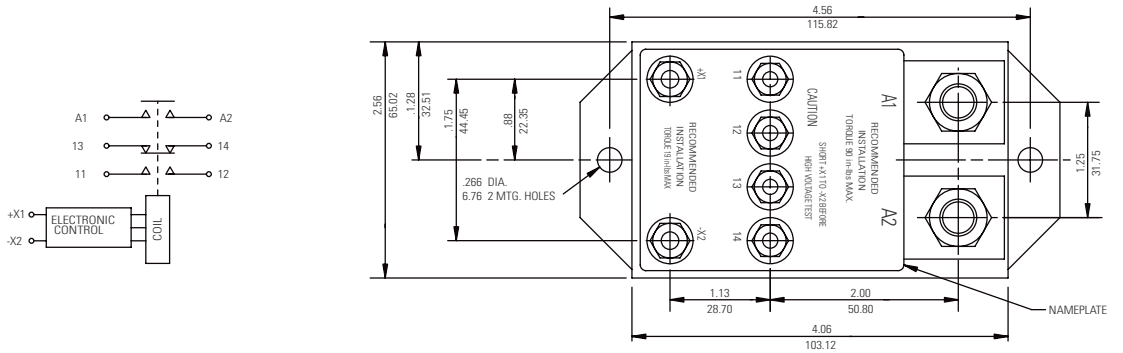

MIL P/N Cross Reference

MIL P/N	Safran Electrical & Power P/N	Page	MIL P/N	Safran Electrical & Power P/N	Page	MIL P/N	Safran Electrical & Power P/N	Page	MIL P/N	Safran Electrical & Power P/N	Page
M6106/9-001	SM15CWD1	36	M83383/02-06	SM600BA25A1	3	MS24166-D1	6041H200	19	MS24376-A2	6042H148	24/26
M6106/9-002	SM15CXD1	36	M83383/02-07	SM600BA35A1	3	MS24166-D2	6041H201	19	MS24376-A3	6042H288	24/26
M6106/10-001	SM15AWD1	36	M83383/02-08	SM600BA40A1	3	MS24168-A3	6042H289	24/26	MS24376-A4	6042H285	24/26
M6106/10-002	SM15AXD1	36	M83383/02-09	SM600BA50A1	3	MS24168-A4	6042H286	24/26	MS24376-D1	6042H145	24/26
M6106/10-005	SM15AWD3	36	M83383/02-10	SM600BA60A1	3	MS24168-D1	6042H161	24/26	MS24376-D2	6042H146	24/26
M6106/11-001	SM15BWD1	36	M83383/02-11	SM600BA75A1	3	MS24168-D2	6042H162	24/26	MS25030-D1B	6046H51	19
M6106/11-002	SM15BXD1	36	M83383/02-13	SM600BA100A1	3	MS24171-D1	6041H215	19	MS25031-D1B	6046H53	19
			M83383/04-03	SM601BA10A1	3	MS24171-D2	6041H202	19	MS25032-D1	6046H46	19
			M83383/04-04	SM601BA15A1	3	MS24172-D1	6041H216	19	MS27242-1	6042H181	24/26
M83383/01-01	SM600BA5N1	3	M83383/04-05	SM601BA20A1	3	MS24172-D2	6041H203	19	MS27242-2	6042H182	24/26
M83383/01-03	SM600BA10N1	3	M83383/04-07	SM601BA35A1	3	MS24178-D1	6041H219	19	MS27243-1	49-2661	23
M83383/01-04	SM600BA15N1	3	M83383/04-08	SM601BA40A1	3				MS27243-2	49-2665	23
M83383/01-05	SM600BA20N1	3	M83383/04-10	SM601BA60A1	3				MS27243-3	49-2667	23
M83383/01-06	SM600BA25N1	3	MS24140-D1	6042H155	24/26	MS24182-D1	6042H166	19	MS27243-4	49-2670	23
M83383/01-07	SM600BA35N1	3	MS24140-D2	6042H156	24/26	MS24183-D1	6042H167	19	MS27243-5	49-2672	23
M83383/01-08	SM600BA40N1	3	MS24141-D1	6042H159	24/26	MS24184-D1	6042H153	19	MS27243-6	49-3179	23
M83383/01-09	SM600BA50N1	3	MS24141-D2	6042H160	24/26	MS24184-D2	6042H154	19	MS27997-D1	6042H91	24/26
M83383/01-10	SM600BA60N1	3	MS24142-D1	6042H151	24/26	MS24185-D1	6041H217	19	MS27997-D2	6042H92	24/26
M83383/01-11	SM600BA75N1	3	MS24142-D2	6042H152	24/26	MS24185-D2	6041H205	19	AN3362	6041H209-1	19
M83383/01-13	SM600BA100N1	3	MS24143-A3	6042H290	24/26	MS24187-D1	6041H220	19			
M83383/02-01	SM600BA5A1	3	MS24143-A4	6042H291	24/26	MS24187-D2	6041H230	19			
M83383/02-03	SM600BA10A1	3	MS24143-D1	6042H141	24/26	MS24192-D1	9565H2	19			
M83383/02-04	SM600BA15A1	3	MS24143-D2	6042H142	24/26	MS24193-D1	9565H94	19			
M83383/02-05	SM600BA20A1	3	MS24143-D3	6042H110	24/26	MS24376-A1	6042H147	24/26			

Product Application Information and Warranty Disclaimer

It is buyer's responsibility to determine the suitability of the particular device for its application, and Safran Electrical & Power makes no warranties, and assumes no liability as to the suitability of sufficiency for buyer's application of the device. Ratings and switch performance are valid only on devices which have not been subjected to unauthorized modifications or misapplications. Dimensional drawings are available upon request.



Notice

The use of Safran Electrical & Power devices should be in accordance with the provisions of the National Electric Code, U.L. and/or other local, military or industry standards that are pertinent to the particular end use. Installation or use not in accordance with these codes and standards could be hazardous to personnel and/or equipment.

Government Cage Code The Government Cage Code for products manufactured by Safran Electrical & Power are 81640 and 76374.

Export Controls Compliance

Reminder to our catalog customers, product in this catalog, if exported, is subject to United States Export Control regulations. Safran Electrical & Power encourages our customers to understand the regulations and ensure compliance, including obtaining written U.S. government authorizations when applicable.

Need additional information not contained in this catalog? For technical questions, application assistance, or the name of your local authorized distributor, call 1-800-955-7354.



Local contact (Sarasota, FL):

SAFRAN ELECTRICAL & POWER

2250 Whitfield Avenue

Sarasota, FL 34243 USA

Tel. 1-800-955-7354 Fax 941-751-7173

TechnicalSupport.SRQ@SafranGroup.com

SAFRAN ELECTRICAL & POWER

Headquarters : 36 rue Raymond Grimaud 31700 BLAGNAC - FRANCE

Tél. +33 (0)5 34 60 00 00 - Fax +33 (0)5 34 60 01 99

www.safran-electrical-power.com

